

# SmartJoist Design Guide





# Introducing the SmartFloor...

the next innovation in SmartJoist design and technology.

Now your SmartJoists can be supplied precision docked\* with the web penetrations precut to your specifications. Each joist comes labeled with its identifying number to match the colour A3 joist layout supplied. This provides the builder with a new level of information to aid quick and correct installation, AND allows for easy installation of services.

SmartFloor now combines the benefits of SmartJoists with the flexibility of open webbed floor trusses.

## Now that's a SmartFloor!

Frame & Truss Industry



Building Design CAD



Import Wall Layout & CAD files



F & T using SmartFrame Software



Export for processing

A3 Layout

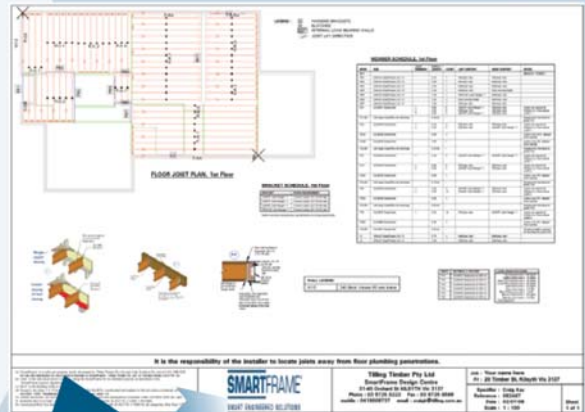

B2B

Smart Order



Automated Cutting System  
(includes precutting web penetrations)

Individual Joist Identification Marking



Precise web penetrations

**SMARTFRAME**<sup>®</sup>

SMART ENGINEERED SOLUTIONS  
leaders in Engineered Wood Products—ALWAYS

\*supplied to the usual nearest 300mm, or we now supply to 100 mm or more especially precision cut to exact length

For more information **1300 668 690** or visit [www.tilling.com.au](http://www.tilling.com.au)

# SmartJoist® DESIGN GUIDE

## TABLE OF CONTENTS

SCOPE and GENERAL PRODUCT INFORMATION	1
ABOUT FLOOR PERFORMANCE	3
RECOMMENDED MAXIMUM SPANS FOR RESIDENTIAL FLOORS	4
JOIST HANGER DETAILS	5
SAFETY WARNING	6
HANDLING AND STORAGE	6
DURABILITY AND EXPOSURE TO MOISTURE	7
GENERAL NOTES	7
TYPICAL SmartJoist FLOOR DETAILS	
Blocking and Lateral Restraint	
- General Notes	8
- 1.0 Joists Bearing onto Exterior Walls	8
- 2.0 Interior Supports	9
BLOCKING AND WALL PLATES	9
FIELD REPAIRS TO DAMAGED SmartJoists	10
TYPICAL SmartJoist FLOOR FRAMING - General Arrangement	11
TYPICAL SmartJoist FLOOR CONSTRUCTION DETAILS	11
BACKER and FILLER BLOCKS	13
FASTENER SPACING	12
LIMITED END NOTCHING AT SUPPORTS	14
FIXING TO STEEL BEAMS	14
FIXING TO BRICK OR MASONRY WALLS	15
TIE DOWN (BRACING) DETAILS	15
JOIST/BEAM CONNECTIONS SUPPORTING OFFSET LOAD BEARING WALLS	16
BEAMS SUPPORTING SmartJoists - MULTIPLE MEMBER LAMINATIONS	18
BRICK LEDGE CANTILEVERS	19
RAFTER CUTS FOR SmartJoists	20
OBLIQUE CONNECTION OPTIONS	20
SmartJoist HOLE AND DUCT CHART	21
OPENINGS WITHIN SmartFrame FLOORS	22
SmartJoist CANTILEVERS SUPPORTING LOAD BEARING WALLS	23
SmartJoist SUPPORTING PARALLEL LOAD BEARING WALLS	25
SmartRim HOLE SPECIFICATIONS	27
SmartJoist ROOF DETAILS	28
TYPICAL SmartJoist ROOF DETAILS	29
SmartJoist RAFTER TIE-DOWN	30
SmartJoist RAFTER BOX GUTTER DETAILS	30
GENERAL CONNECTOR INSTALLATION	31
FIRE SAFETY AND SOUND TRANSMISSION	
- Fire Rated floors/ceilings	32
- Sound Transmission	32
SmartGuard TREATMENT	33
ADHESIVE AND FORMALDEHYDE EMISSIONS	33
DrillMate® Web Hole Saw	34

# SCOPE OF THIS PUBLICATION

This Design Guide and Load Tables assists in the selection of SmartJoists for most of the common structural arrangements met in domestic construction. The Smart-Frame computer software, in conjunction with this manual, provides an unparalleled level of design capacity for engineered timber products.

While specific details are given on suitable methods of developing lateral restraint, the methods of providing adequate support, adequate anchorage against wind uplift and overall structural stability are outside the scope of this publication.

Information on the above matters can be obtained from AS1684 Residential timber-framed construction code or from a structural engineer experienced in timber construction.

Tilling Timber Pty Ltd has structural engineers on staff who can be contacted for advice on matters concerning the use of its engineered timber products in timber construction on the SmartData Customer HelpLine on 1300 668 690 or at smartdata@tilling.com.au.

## SUBSTITUTION OF OTHER PRODUCTS

All load tables in this document are designed using in-grade tested properties for SmartJoists as manufactured by Pacific Woodtech Corporation of Washington State, USA. Other manufacturers I-Joists may have different properties and, therefore, cannot be designed using these span tables.

## COPYRIGHT

Copyright of this publication remains the property of Tilling Timber Pty Ltd, and reproduction of the whole or part of this publication without written permission from Tilling Timber Pty Ltd is prohibited.

## CERTIFICATION

As a professional engineer, qualified and experienced in timber engineering, I certify that the use of the SmartJoist members as shown in these tables, and installed in accordance with the provisions of this Design Guide, will comply with the requirements of the Building Code of Australia. These span tables have been prepared in accordance with standard engineering principles, the relevant test reports and Australian standards, i.e. -

- AS 1684.1 Residential timber-framed construction
- AS 1170.1 Structural Design Actions – Permanent Imposed and other actions
- AS 1720.1 Timber Structures - Design Methods
- AS 4055 Wind loads for Houses
- ASTM D 5055 Standard specification for establishing and monitoring structural capacities of pre-fabricated wood I-Joists

*Craig Kay*

Craig Kay, PEng, EC1961, RPEQ5100, BPB0730, CC5635C, NPBR  
National Product Manager - EWVP

Web thickness 44, 51 58 and 70 mm flanges: 9.5 mm, 90 mm flanges: 11.5 mm

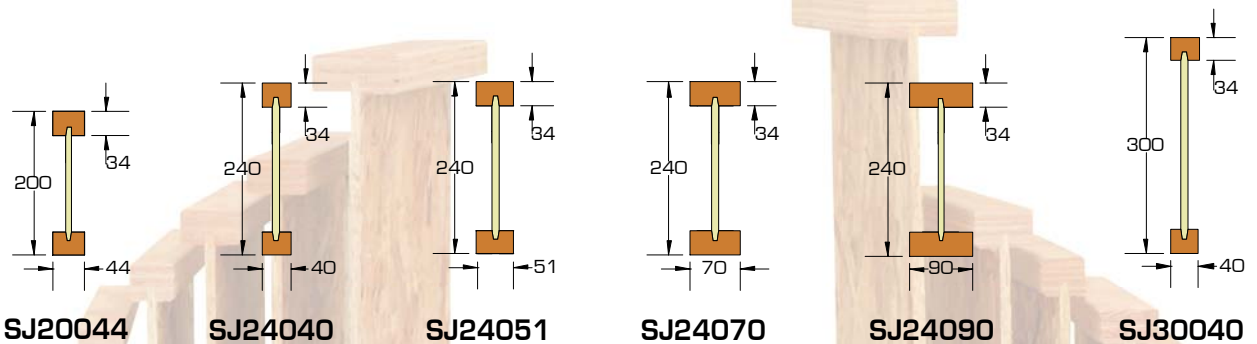

SmartJoist sizes available in each state may vary from time to time. Check you local stockist before ordering

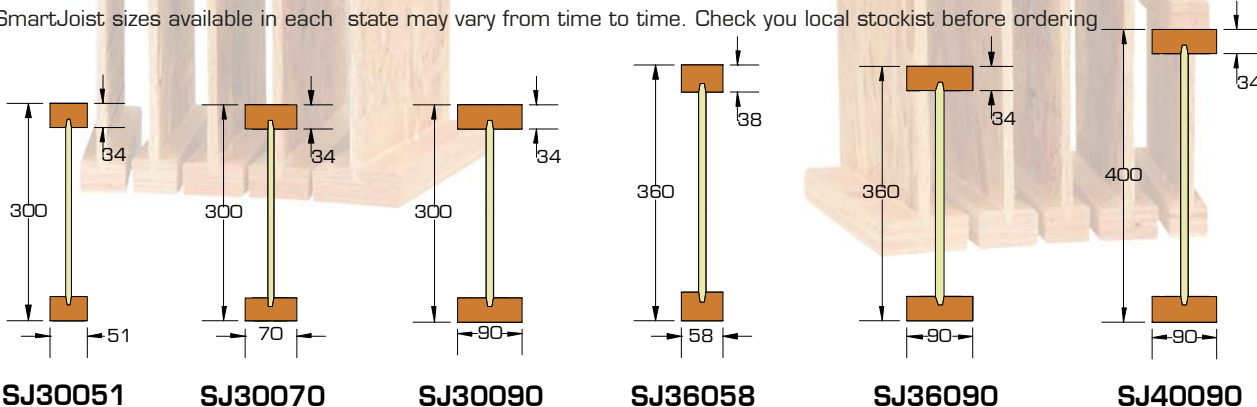

SmartJoist dimension tolerances: depth: +0 -3 mm, Flange width: +/- 1 mm, flange thickness: no plus limitation -2 mm.

The SmartFrame Engineered Timber System is made up of:

- World class engineered timber products:
  - i. SmartJoists
  - ii. SmartLVL's
  - iii. SmartLam Glulam
  - iv. Unique Structural Design, Detailing and Estimating Software
- Full engineering support and technical advice from experienced engineers and field staff free of charge on our unique SmartData Customer HelpLine 1300 668 690

### SmartJoists.

The strength is in the engineering:- Strong. Stiff. Reliable. SmartJoists are engineered for heavy performance. We start with ultrasonically graded LVL, bonded with exterior adhesive for more load carrying capacity.

The webs are made from stable, strong Oriented Strand Board (OSB) for superior strength and consistent performance. SmartJoists are more uniform than solid sawn joists. They stay straighter and are manufactured with no camber, so there is no chance of crown down or upside down installation. They resist shrinking, twisting, warping and splitting for squeak resistant floors and quality roofs and ceilings.

Holes may be easily cut in the web according to the tables on page 22, allowing ducts and utilities to be run through the joists. Pre-punched 40 mm knockout holes are provided in the web for small diameter services or wiring.

**Save Time and Money:-** Because they weigh less than solid sawn joists, SmartJoists are easier to install, saving construction time and cost. Their greater load carrying capacity allows you to space them further apart, so it takes fewer to build the average floor or roof. And with five (5) depths from 200 to 400 mm, you will never have to compromise

your design. So whether your plans call for cantilever beams in balconies, cathedral roofs or high pitched roof slopes, SmartJoists are the perfect choice.

**An Environmentally Sound Choice:-** In addition to being cost effective, SmartJoists are also an environmentally sound choice because they are made of a renewable resource – wood. So they are a better choice for building.

**SmartFrame Software:-** Our unique SmartFrame design, detailing and estimating software offers you unparalleled design and estimating capabilities with engineered timber. You will get accurate designs for a wide variety of applications, printouts and joist layouts.

### Limitations of use - SmartJoists.

SmartJoists are to be used in dry interior environments only, fully enclosed from exposure to exterior moisture. SmartJoists are suitable for subfloor applications provided that the subfloor space is ventilated as per the BCA requirements. This means that SmartJoists must not be exposed to environments where the equilibrium moisture content of the joist will exceed 18%. Tilling Timber will not guarantee SmartJoists that have been left exposed to the weather either prior to or during construction for more than 90 days.

Detailing such as cladding or lining must be used in moisture laden environments (commercial kitchens, bathrooms, wet industrial areas, saunas, swimming pool and spa rooms etc.) and constructed in such a way as to prevent exposure of the SmartJoist to moisture.

SmartJoists may be used in applications which are often exposed externally (gable ends, eaves, floor joists applications in elevated houses, cantilevered joists etc.) but must be sufficiently enclosed with a suitable cladding, lining etc. to completely prevent the exposure of the SmartJoist to moisture.

## SmartFrame Consumer Product Warranty

Tilling Timber guarantees that SmartFrame Engineered Timber products have been manufactured to exacting standards and are free from defects in workmanship and materials.

At Tilling Timber, we take great pride in SmartFrame products, so if you bring to our attention problems such as squeaks that you believe are caused by our products, we guarantee that a technical representative will contact you promptly to evaluate the issues and provide advice to help solve the problem

Providing that any SmartFrame product is correctly designed, handled and installed, any problem caused by an unlikely defect will promptly be remedied at no cost to you.

This guarantee remains valid for the expected life of your home.

Tilling Timber – Proudly Australian owned and operated.

**Priority call: 1300 668 690 e-mail: smartdata@tilling.com.au**

## GENERAL INFORMATION - ABOUT FLOOR PERFORMANCE

The "feeling" that is identified when a person walks on a floor is very subjective. Some people want to feel a very stiff floor and others want some "give" so that it softens the footing. When people say the floor "bounces", it may be vibrating. This sensation is often caused by lack of dead load such as furniture, direct applied ceilings or other materials to absorb or dampen the vibration.

The allowable spans shown in the tables of this manual have been designed to meet the strength and serviceability criteria in AS1684.1. This standard introduced a further serviceability equation into the design of floor joists which checked the deflection caused by a 1.0 kN load applied at mid-span. If the differential deflection of the joist relative to an adjacent joist exceeds 2.0 mm then the span is deemed to be such that the floor performance may be considered too bouncy for service.

### FACTORS THAT CAN AFFECT FLOOR DYNAMIC PERFORMANCE.

- The choice of flooring system
- The depth, stiffness and mass of the joists
- Spacing of joists
- Fixing of sheathing to joists
- Stiffness and mass of floor sheathing
- Mass and stiffness of ceiling materials
- Method of installation
- Location and type of internal partitions and furniture

### FACTORS THAT CAN IMPROVE FLOOR DYNAMIC PERFORMANCE.

- Glue-nailed floors will perform better than floors secured by nails alone.
- Deflection of the sheathing material between joists can be reduced by decreasing the joist spacing or using a thicker and/or stiffer sheathing.
- Proper installation is essential for dependable performance. Adequate and level support for the joists is necessary, as is correct fastening of the joists and sheathing.
- The installation of a ceiling to the bottom flange of the joists.
- Between joist blocking can provide some improvement to floor dynamic performance. It is emphasised that for between joist blocking to be effective, it is important that the blocking is continuous, this being easily achieved by the addition of a continuous bottom strap such as hoop iron strapping which is also attached to the end walls.

If floor dynamic performance is a concern to either the client, designer or contractor, then the above variables can be altered to improve dynamic performance. Some stiff floors with very little dead load may tend to vibrate. This can generally be dampened by directly attaching the ceiling below the underside of the joists. Where there is no lining to the underside of the joists, it is recommended that between joist blocking be utilised to dampen this light-weight floor.

If between joist blocking is to be used to improve floor dynamic performance, it is recommended that a blocking system (at least midspan,  $\frac{1}{3}$  points for large open rooms) similar to the one shown below should be adopted.

### BETWEEN JOIST BLOCKING FOR SmartJoists

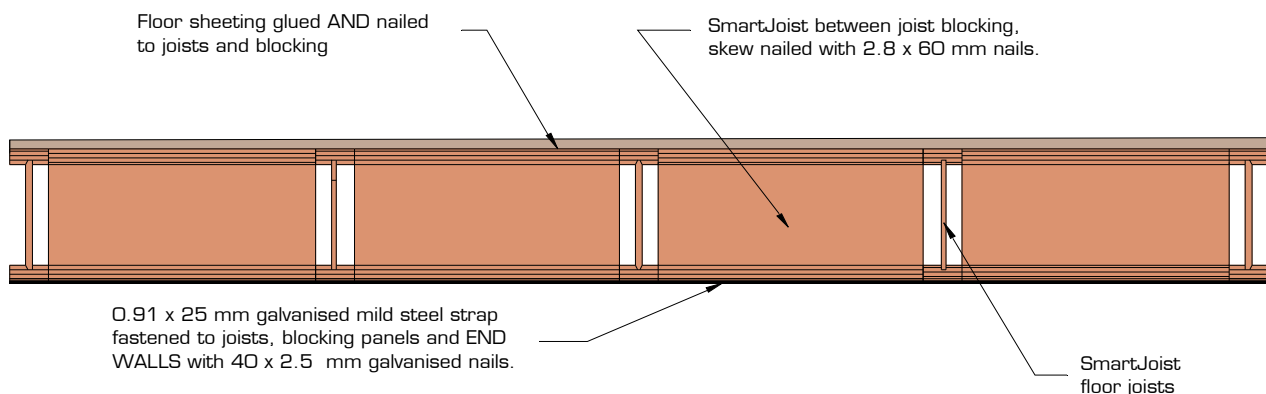

## SmartJoist DESIGN/EFFECTIVE SPAN

Normal structural analysis uses the centreline representation of the member. The term "span" can be defined in a number of ways and these are defined as follows:

**Clear Span.** This is the distance between the faces of any support. It is generally the one easiest to measure and read from the drawings

**Nominal span/centre-line span.** This is the distance between the centre of the supports. This span is used to determine bending moments and deflections for continuous spanning SmartJoist members

**Design span/Effective span.** This is the span used for single span members to determine the bending moment, the slenderness of bending members and the deflections. In AS 1720.1, this is the dimension referred to as "L", and is defined below.

Design span/Effective span is the distance between -

- The centre of the bearing at each end of a beam where the bearing lengths have **NOT** been conservatively sized
- The centre of notional bearing that have been sized appropriately, where the size of the bearing **IS** conservative.

Diagram (a) shows beam where bearings have been designed appropriately. The effective span is taken as the distance between the centre of each bearing area

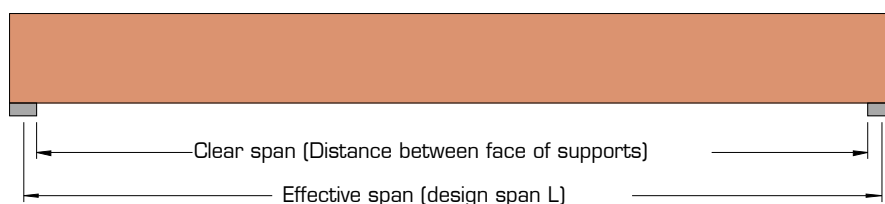
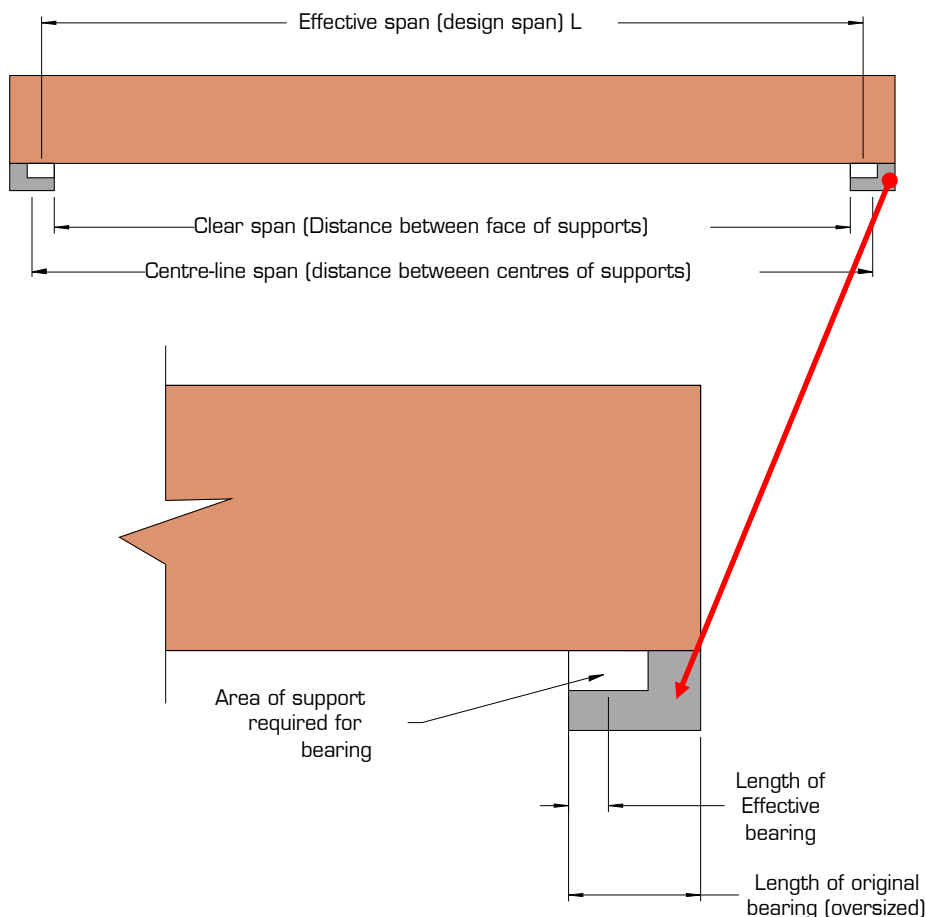

Diagram (b) shows beam where bearings at each end have been oversized. (This is frequently the case for beams that bear onto brickwork or concrete walls where the thickness of the wall is in excess of the area required to give the beam bearing capacity).

To find the correct effective span:

1. Calculate the minimum bearing required to carry the loads satisfactorily
2. Add minimum bearing length to "clear span" distance



# RECOMMENDED MAXIMUM SPANS FOR RESIDENTIAL FLOORS

## GENERAL DOMESTIC - 1.5 kPa

Loadings: Permanent Loading G: self weight + 40 kg/m<sup>2</sup> + 0.6 kPa of live load permanently applied, live load Q: 1.5 kPa or 1.8 kN point live load

Joist spacing (mm)		300	400	450	600	300	400	450	600
SmartJoist Code	Self Weight (kg/m)	Maximum floor Joist span (mm)							
		Single span				Continuous span			
SJ20044	2.8	4700	4350	4100	3700	5450	5000	4900	4350
SJ24040	3.0	5100	4750	4600	4200	5950	5500	5350	4900
SJ24051	3.4	5400	5000	4900	4500	6300	5800	5650	5200
SJ24070	4.0	5800	5400	5200	4850	6700	6200	6000	5500
SJ24090	5.0	6150	5700	5600	5100	7200	6650	6450	5950
SJ30040	3.4	5900	5400	5300	4900	6800	6300	6100	5650
SJ30051	3.9	6200	5700	5600	5150	7200	6650	6450	5900
SJ30070	4.3	6600	6100	6000	5500	7600	7100	6800	6300
SJ30090	5.5	6950	6500	6300	5900	8150	7550	7300	6700
SJ36058	4.8	7150	6600	6500	6000	8300	7700	7400	6900
SJ36090	5.9	7700	7200	7000	6500	9050	8400	8100	7500
SJ40090	6.2	8150	7300	7500	6900	9600	8900	8650	7800

In compiling the span tables in this manual, the requirements of the relevant Australian standards and codes along with established Industry standard design guidelines for Residential Construction have been followed. In particular, the following codes and references have been used:

- AS 1684.1 Residential timber-framed construction
- AS 1170.1 Structural design actions – permanent imposed and other actions
- AS 1720.1 Timber Structures - design methods
- AS 4055 Wind loads for houses
- AS/NZS 4063 Characterization of structural timber
- ASTM D 5055 Standard specification for establishing and monitoring structural capacities of prefabricated wood I-Joists

### SERVICEABILITY CRITERIA:

Max dead load deflection - lesser of span / 300 or 15 mm ( $j_2 = 2$ )  
 Max live load deflection - lesser of span / 360 or 9 mm

### FLOOR DYNAMIC PERFORMANCE CRITERIA:

Minimum Natural Frequency - 8 Hertz  
 Maximum differential deflection between Joists of 2 mm under a concentrated load of 1.0 kN mid-span.

### FLOORING:

Spans are suitable for solid timber, particle board and ply flooring. Floor sheathing glued and nailed to the joists will improve floor rigidity. Where a heavy overlay material is to be applied, such as thick mortar bed tiled or slate floors, the permanent load allowance should be increased to 1.2 kPa. A reduction of joist spacing can be used to accommodate this extra permanent load. A satisfactory result can be achieved by adopting the maximum spans for 600 mm and 450 mm spacings but installing the joists at 450 mm and 300 mm spacings respectively.

### CONTINUOUS SPANS:

For beams which are continuous over two unequal spans, the design span and the "resultant span description" depend on the percentage difference between the two spans as shown below:

Span difference	Effective span	Resultant span description
10% max	main span	continuous
10 - 30%	1.1 x main span	continuous
above 30% diff	main span	single

$$\text{span difference} = \frac{(\text{main span} - \text{second span})}{(\text{main span} + \text{second span})} \times 100$$



# JOIST HANGER DETAILS

## NAILING

Use only the listed galvanised bracket nails. All holes are to be filled with the specified nails in order to achieve the stated hanger capacity. Alternatively, screw with 35 x 6 gauge bugle-head or wafer-head wood screws. The joist hangers below have been developed specifically for SmartJoists. The joist hangers and nails are available from Tilling Timber as part of a SmartFrame order. It is not recommended that joist hangers other than those listed below be used with SmartJoists.

SmartJoists brackets in areas shaded require web stiffeners as per detail F13

SmartJoist	face mount code	hanger capacity $\phi$ kN *	face nail holes	nail size	top mount code	hanger capacity $\phi$ kN *	face nail holes to support	top nail holes	nails to joist	nail size
<b>Single joist face mounts</b>					<b>Single joist top mount</b>					
SJ20044	20044F	6.2	8	3.75 x 40	20044T	4.8	2	4	2	3.75 x 40
SJ24040	24040F	7.8	10	3.75 x 40	24040T	4.8	2	4	2	3.75 x 40
SJ24051	24051F	7.8	10	3.75 x 40	24051T	4.8	2	4	2	3.75 x 40
SJ24070	24070F	7.8	10	3.75 x 40	24070T	4.8	2	4	2	3.75 x 40
SJ24090	24090F	7.8	10	3.75 x 40	24090T	4.8	2	4	2	3.75 x 40
SJ30040	30040F	9.3	12	3.75 x 40	30040T	4.8	2	4	2	3.75 x 40
SJ30051	30051F	9.3	12	3.75 x 40	30051T	4.8	2	4	2	3.75 x 40
SJ30070	30070F	9.3	12	3.75 x 40	30070T	4.8	2	4	2	3.75 x 40
SJ30090	30090F	9.3	12	3.75 x 40	30090T	4.8	2	4	2	3.75 x 40
SJ36058	36058F	10.9	14	3.75 x 40	36058T	4.8	2	4	2	3.75 x 40
SJ36090	36090F	10.9	14	3.75 x 40	36090T	4.8	2	4	2	3.75 x 40
SJ40090	40090F	10.9	14	3.75 x 40	40090T	4.8	2	4	2	3.75 x 40
<b>Double joist face mounts</b>					<b>Double joist top mounts</b>					
2/SJ20044	20044DF	6.2	8	3.75 x 40	N/A					
2/SJ24040	N/A				24040DT					
2/SJ24051	24051DF	7.8	10	3.75 x 40	24051DT	4.8	2	2	4	3.75 x 40
2/SJ24070	24070DF	7.8	10	3.75 x 40	24070DT	4.8	2	2	4	3.75 x 40
2/SJ24090	24090DF	7.8	10	3.75x40	24090DT	5.7	2	4	2	3.75 x 40
2/SJ30040	N/A				N/A					
2/SJ30051	30051DF	8.7	12	3.75 x 40	30051DT	4.8	2	2	4	3.75 x 40
2/SJ30070	30070DF	8.7	12	3.75 x 40	30070DT	4.8	2	2	4	3.75 x 40
2/SJ30090	30090DF	8.7	12	3.75 x 40	30090DT	5.7	2	4	2	3.75 x 40
2/SJ36058	N/A				36058DT	4.8	2	4	2	3.75 x 40
2/SJ36090	N/A				36090DT	5.7	2	4	2	3.75 x 40

### Skewed left or right (face mount)

SmartJoist	SmartFrame code	hanger capacity $\phi$ kN *	face nail holes	Nails to joist	nail size
SJ20044	20044FR or FL	6.2	8	2	3.75 x 40
SJ24040	N/A				
SJ24051 - SJ30051	240-30051FR or FL	6.2	8	2	3.75 x 40
SJ24070	N/A				
SJ24090	24090FR or FL	6.2	8	2	3.75 x 40
SJ30040	N/A				
SJ30051	30051FR or FL	7.8	10	2	3.75 x 40
SJ30090	30090FR or FL	7.8	10	2	3.75 x 40
SJ36058	36058RR or FL	7.8	10	2	3.75 x 40
SJ36090	36090FR or FL	7.8	10	2	3.75 x 40
ALL	LVSIA	5.5	4	1	12 g x 35 screw

### Variable Slope (face mount - usually for rafters)

SmartJoist	SmartFrame code	hanger capacity $\phi$ kN *	face nail holes	Nails to joist	nail size
SJ20044	20044VS	4.6	10	7	3.75 x 40
SJ24051 - SJ30051	240-30051VS	4.6	10	7	3.75 x 40
SJ24070 - SJ30070	N/A				
SJ24090 - SJ40090	240-40090VS	9.9	18	12	3.75 x 40
SJ36058	36058VS	4.6	10	7	3.75 x 40

## NOTES:

\* Hanger capacity is based upon dead load + floor live load for a supporting beam of joint strength JD5.

$k_1 = 0.69$ , Capacity factor  $\phi = 0.85$ . For permanent loads, the above value should be multiplied by  $0.57/0.69 = 0.82$ .

# SAFETY WARNING

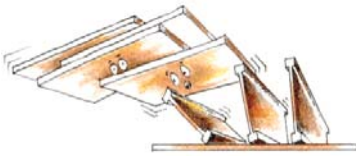

**DO NOT ALLOW WORKERS OR LOADS ON SmartJoists UNTIL ALL BLOCKING, HANGERS, RIM JOISTS, NAILING AND TEMPORARY BRACING ARE INSTALLED AS SPECIFIED BELOW. SERIOUS ACCIDENTS OR INJURY CAN RESULT FROM FAILURE TO FOLLOW THESE GUIDELINES.**



## ACCIDENTS CAN BE AVOIDED UNDER NORMAL CONDITIONS BY FOLLOWING THESE GUIDELINES:

1. Brace each joist as it is erected. Joists must be nailed to supports and all hangers, blocking, rim joists. X - bridging at supports must be completely installed and properly nailed. (see general notes and details)
2. Brace the ends of cantilevers (overhangs) with closure panels, rim joist or x - bridging (see general notes and details)
3. Lateral brace the top flange of each joist, to prevent sideways buckling or rollover which may occur under light construction loads, such as a worker and/or a layer of un-nailed sheathing. Fully installed

permanent sheathing or temporary struts to the top flange of each joist (see 'Typical SmartJoist floor framing') can accomplish lateral bracing. Temporary struts must be nailed to a lateral restraint at the end of bay such as a braced wall or temporary (or permanent) sheathing nailed to the first 1200 mm of the joist at the end of the bay (see 'Typical floor or roof framing')

4. Permanent sheathing must be completely installed and properly nailed before additional loads can be placed on the system
5. **The integrity and safe use of these products can be seriously impaired if they are damaged. Do not install any damaged products. Contact your Tiling representative or the SmartData Customer Helpline on 1300 668 690 if any product damage is noted.**

## HANDLING AND STORAGE OF SmartJoists

- Store SmartJoists flat on a hard, dry surface
- If surface isn't paved, the ground should be covered with a polythene film
- Keep covered with waterproof material that allows bundles to "breathe"
- Use bearers (bolsters) between the ground and the first bundle (4 metre max spacing)
- Use 100 x 50 timber flat between bundles at same spacing as bolsters
- Take great care to rewrap remaining material after opening bundles
- Wood "grows" in thickness and depth when allowed to get wet....KEEP DRY!
- Wood with high MC has short term reduction in Characteristic Strengths .... KEEP DRY!
- Under NO circumstances are stored SmartJoists to be in contact with the ground.

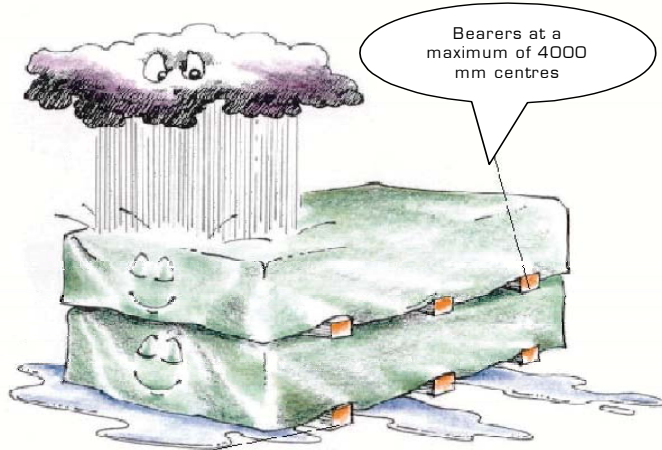

Use bearers to keep stacked material away from damp surfaces. Align bearer vertically

SmartJoists should be stacked in the upright position to avoid any damage

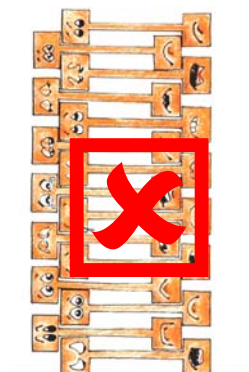
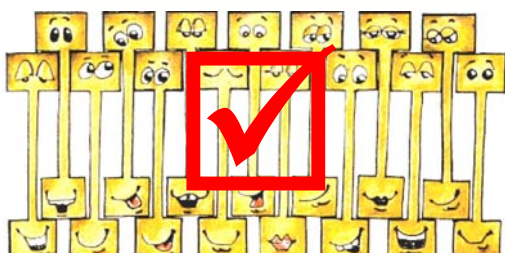

## DURABILITY AND EXPOSURE TO MOISTURE

SmartJoists are manufactured with Douglas Fir (Oregon) flanges with OSB webs, both having a durability rating of class 4, which is the same rating as some Ash type Eucalypts. Untreated SmartJoists should not be used where the equilibrium moisture content is likely to remain above 18 % for an extended period.

Untreated SmartJoists are suitable in the *internal, fully protected, ventilated* and the *external above ground, protected* zones of the structure as shown in appendix B of AS 1684. Untreated SmartJoist is not suitable for *external above ground, exposed* or humid indoor conditions, such as swimming pool enclosures.

### MOISTURE EFFECTS ON SmartJoists

SmartJoist is supplied **WITHOUT** any short term construction sealer, but once framed into a structure may be exposed to the weather for a limited time (not greater than 3 months) without negative affect, **BUT**, it may exhibit some effects of this exposure.

The wood fibre in SmartJoists, like all wood products, is hygroscopic, which means it has an affinity for water. The wood fibre in SmartJoist will readily take up and release moisture in response to changes in the local environment. Moisture exposure will lead to dimensional change. While the products will withstand normal exposure, excessive exposure during distribution, storage or construction may lead to dimensional changes that affect serviceability. These changes include twisting, bowing or expansion to dimen-

sions to beyond the specified tolerance of the product in the "as-manufactured" condition.

As an organic material, mold and mildew may grow on untreated wood products if moisture is present. Prolonged periods of high moisture may also support the growth of wood decay fungi, which is another reason to follow proper methods of storage and handling of SmartJoists.

The table below shows the moisture content of SmartJoists as a function of humidity.

Moisture content of wood products %<sup>(1)</sup>

Relative Humidity %	LVL Flange MC	OSB web
10	1.2	0.8
20	2.8	1.0
30	4.6	2.0
40	5.8	3.6
50	7.0	5.2
60	8.4	6.3
70	11.1	8.9
80	15.3	13.1
90	19.4	17.2

(1). Approximate moisture content at 21°C

Wetting during construction may lead to temporary elevated moisture content and dimensional changes. Once covered, the SmartJoists will ultimately dry and re-equilibrate to the ambient humidity conditions, but some expansion or swelling may remain after drying.

## SmartJoists - GENERAL NOTES

Do NOT start toe nail into the corner of the flange or the top of the flange.

MAXIMUM Nail diameter 3.15 mm

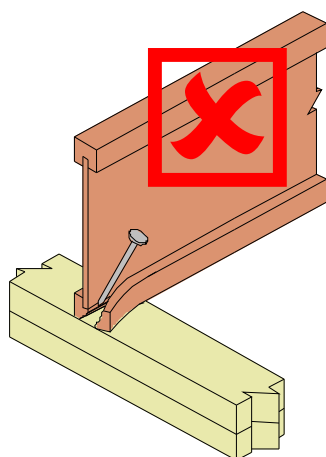

Start toe nail approximately 2/3 up the side of the flange.

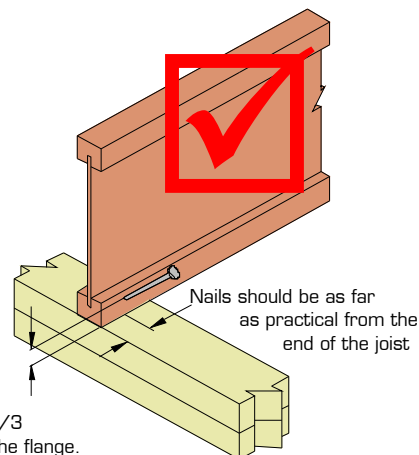

- Except where otherwise noted, 30 mm minimum bearing is required at joist ends and 42 mm minimum bearing is required at intermediate supports.
- Nail joists at each bearing with 2 of 3.15  $\Phi$  x 65 nails, using one each side placed 30 mm from the end to avoid splitting.
- SmartJoist blocking or SmartRim - face nail to bearing plate with 3.15  $\Phi$  x 65 nails at 150 mm centres. Nail rim joist to the end of the top and bottom flange of each SmartJoist with 1 3.15  $\Phi$  x 65 nail, use 1 3.75  $\Phi$  x 75 nail top and bottom with joists with 58, 70 or 90 mm wide flanges.
- 19 mm SmartRim - toe nail to bearing plate with 3.15  $\Phi$  x 65 nails at 150 centres or 4.5  $\Phi$  x 75 nails at 300 centres. Nail rim to the end of the top and bottom flanges of each SmartJoist with 1 3.15  $\Phi$  x 65 nails.
- Sheathing nailing to top flange (Joists must be fully braced before sheathing is nailed)
  - Space 2.8  $\Phi$  x 65 and 3.15  $\Phi$  x 65 nails no closer than 50 mm per row.
  - Space 3.75 x 75 nails no closer than 75 mm.
  - Maximum nail spacing: 300 mm

## SmartJoists - GENERAL NOTES (Cont'd)

6. Backer blocks at hanger details:  
40 mm flanges - 15 mm ply  
44 & 51 mm flange - 19 mm ply  
58 mm flange - 2 pieces of 12 mm ply  
70 mm flange - 2 pieces of 15 mm ply  
90 mm flange - 2 pieces of 19 mm ply
7. See double SmartJoist detail F15 for filler blocks. Nail Joists together with two rows of 3.75  $\Phi$  x 75 nails on each side of double joist at 300 mm centres (Clinch if possible). A total of 4 nails per 300 mm is required. If nails can be clinched, only 2 nails per 300 mm is required.
8. All joists require lateral support at end bearings using blocking or rim material.
9. The top flanges must be kept straight within 10 mm of the true alignment.
10. See web stiffener detail F13 for web stiffener attachment at supports. Web stiffener requirements for concentrated loads in excess of 4.5 kN, applied at the top flange of the joist, requires additional consideration.
11. When required, install web stiffeners to joist (see detail F13) prior to placing joist in the hanger, then nail hanger to joist.
12. All roof details are valid to a maximum angle of 35° (as per AS1684)
13. All nails are steel nails complying with AS 2334 - 1980 Steel nails - Metric series. Nail gun nails of similar length and diameter may be substituted for the above provided that they are manufactured with properties equivalent to the nails in the above code.
14. Install all hangers to the manufacturers installation instructions, taking particular attention to the use of the correct nails. Never use clouts or brads.
15. Prescriptive code requirements for mid span blocking of solid timber joists are not applicable to SmartJoists.

## TYPICAL SmartJoist FLOOR DETAILS

### BLOCKING AND LATERAL RESTRAINT

#### GENERAL NOTES:

SmartJoists designed and constructed as per this Design Guide do not require mid-span blocking. The exception to this is for lightweight subfloors where there is no lining to the underside of the joists. For more information on this topic, see page 3 'ABOUT FLOOR PERFORMANCE'.

Blocking within a structure falls within two (2) quite distinct stages:

**Temporary** or during construction blocking to prevent roll over of joists before the installation of floor sheeting.

**Permanent** blocking to provide resistance to racking loads through the floor diaphragm, transfer of vertical wall loads and to provide torsional resistance to the end of the joist.

The provision contained within AS1684 Residential timber-framed construction code dealing with blocking for deep joists, is "during construction" or "temporary" blocking, designed only to prevent the roll over of the deep joists prior to the floor sheeting being attached. This level of blocking can form a part of any overall blocking system, but was never intended to provide the total amount of racking resistance or vertical load transfer requirements within this floor diaphragm.

The lateral bracing requirements of the structure, unless there is full blocking of exterior walls, must be calculated in each individual case. Advice on this matter is obtainable from AS1684 Residential timber-framed construction code.

### 1.0 JOISTS BEARING ONTO EXTERNAL WALLS

#### 1.1 LOADS AT JOIST/SUPPORT CONNECTION

The ends of floor joists that bear onto a support experience external loads other than the floor dead and live loads, as shown. Any I-Joist, with its small cross sectional area, needs to have its end bearing capacity considered as part of the design process.

11. When required, install web stiffeners to joist (see detail F13) prior to placing joist in the hanger, then nail hanger to joist.
12. All roof details are valid to a maximum angle of 35° (as per AS1684)
13. All nails are steel nails complying with AS 2334 - 1980 Steel nails - Metric series. Nail gun nails of similar length and diameter may be substituted for the above provided that they are manufactured with properties equivalent to the nails in the above code.
14. Install all hangers to the manufacturers installation instructions, taking particular attention to the use of the correct nails. Never use clouts or brads.
15. Prescriptive code requirements for mid span blocking of solid timber joists are not applicable to SmartJoists.

Further, as a holistic approach to the consideration of the lateral stability of the complete structure, it is necessary to consider the availability of racking and shear resistance through the floor diaphragm.

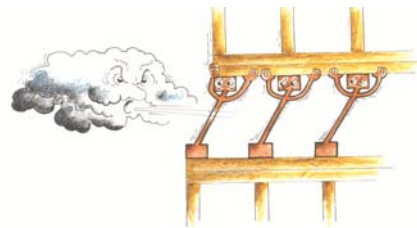

1. Racking and shear effects due to wind and earthquake loads
2. Vertical loads on joists due to upper wall, floors and roof.

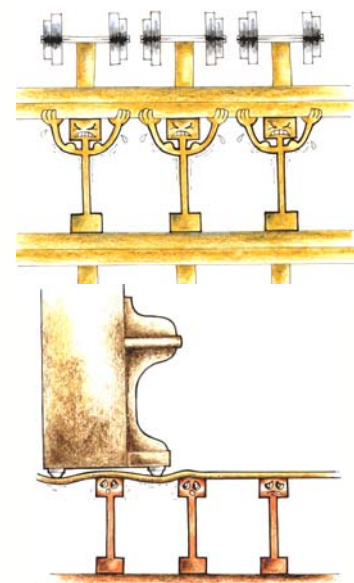

3. Unsightly deflections in the edges of unsupported sheet flooring may be experienced if heavy items of furniture are placed close to sheet edges.

# TYPICAL SmartJoist FLOOR DETAILS (Cont'd)

## 1.2 STAGES OF BLOCKING/BRACING

### 1.2.1 TEMPORARY (DURING CONSTRUCTION) END BLOCKING

Temporary or during construction blocking of the ends of joists over external wall must comply with the requirements as shown in the "SAFETY WARNING" on page 7 and as shown in the "TYPICAL SmartJoist FLOOR FRAMING" diagram on page 12.

This is summarised as:

- Temporary struts, fastened to top of SmartJoist, connected back to braced supports.
- Temporary floor sheeting nailed to the first 1200 mm of joists at the end of the bay, in combination with struts, if no connection to a braced wall can be made.

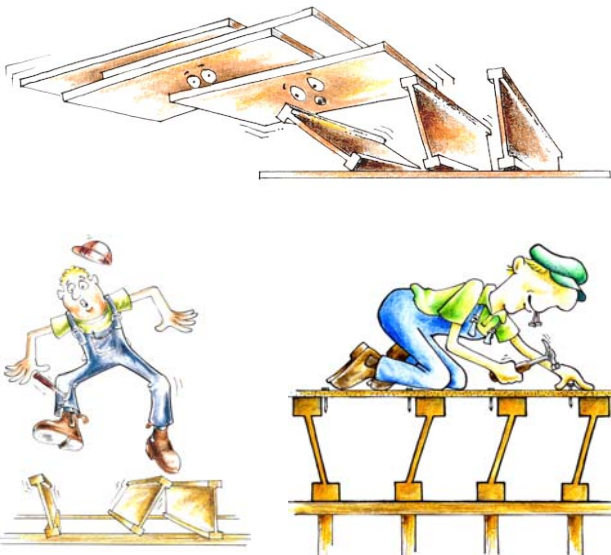

### 1.2.2 PERMANENT END BLOCKING/BRACING

Permanent blocking (bracing) to be effective in providing adequate transfer of racking and shear loads through the floor diaphragm must comply with the details as shown in "TYPICAL SmartJoist FRAMING" diagram on page 12. In essence, fully block the ends of all joists at their bearing point on external walls, as per one of the options shown in details F1- F4.

This permanent blocking/bracing provides:

1. A satisfactory mechanism to transfer racking loads through the floor diaphragm.
2. Vertical load transfer independent of the floor joist.
3. Support to the end of the floor sheeting (Platform floors only). Heavily loaded furniture legs have been known to cause large deflections and even failures at the edges of sheet flooring.
4. Torsional restraint to the end of floor joists, improving the joists structural performance.

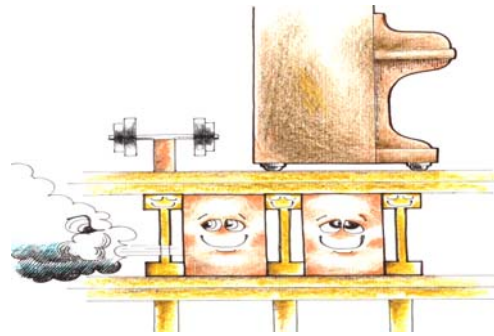

## 2.0 INTERIOR SUPPORTS

### 2.1 ENDS OF SIMPLE SPANS

Where SmartJoists are discontinuous over interior supports, install the temporary strut bracing as per "SAFETY WARNING" on page 7.

### 2.2 CONTINUOUS SPANS

Continuous joists over internal supports do not require blocking, other than the temporary top flange struts as shown in the "SAFETY WARNING" on page 7, except in the following circumstances:

- Load bearing walls bear onto the joists at their support. (Details F7 or F8 apply)
- Shear resistance is required in internal walls (This is a function of shear resistance, and is not related to the structural adequacy of the joist itself.)

## 3.0 BLOCKING AND WALL PLATES

Wall plates in the frame are required to transfer vertical loads into the support structure below. These wall plates may be supported at 450 or 600 mm ctrs, thus acting as a beam between supports, bending about its weaker axis. When concentrated loads act at the centre of this wall plate, the bending and deflection effects can be quite significant. The full blocking of external and load bearing walls, as shown in details F1-F4, can act as a beam transferring these loads to the support structure below, thus reducing the beam effect of the wall plates.

Unless there is a requirement for double wall plates for a reason OTHER than the beam effect between supports, walls blocked as per detail F1-F4 and general notes #2, #3, and #4 provide sufficient beam action to allow single wall plates.

### WALL AND ROOF LOADINGS

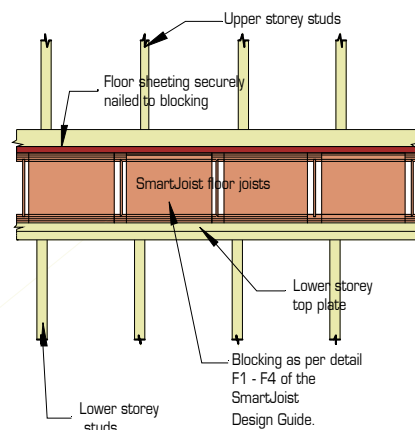

## FIELD REPAIRS TO DAMAGED SmartJoists

**DON'T MAKE HOLES WITH HAMMER OTHER THAN PRE-PUNCHED KNOCKOUTS**

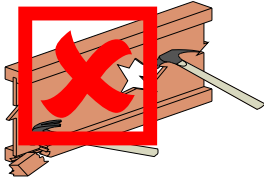

**DON'T HAMMER ON FLANGES AND DAMAGE JOINT**

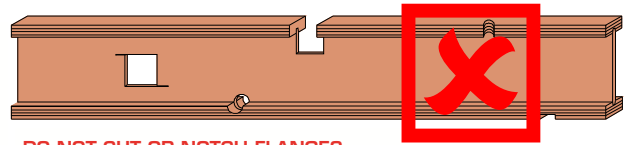

**DO NOT CUT OR NOTCH FLANGES  
DO NOT OVER-CUT HOLES IN WEB**

SmartJoists are sophisticated Engineered Timber products, and must be treated accordingly. Damage to key components, while affecting only a small percentage of the cross section may be sufficient to render the SmartJoist unsuitable for the purpose.

It is therefore recommended that damage to joists and the possibility of repair be referred to the SmartData Customer Helpline on 1300 668 690 or at [smartdata@tilling.com.au](mailto:smartdata@tilling.com.au) for advice.

### FLANGE DAMAGE

- Flange damage becomes more critical the nearer it is to mid-span or an interior support. Flange damage is less critical in close proximity to an end support.
- How much flange damage is acceptable? A rule of thumb is "If you have to ask, it's too much". A saw kerf that knicks the corner of a flange on one lightly-loaded joist could well be acceptable.
- A joist with unacceptable flange damage cannot be repaired, rather a new joist must be added to take its place. The damaged joist does not have to be removed. Consult SmartJoist and SmartLVL tables to find an acceptable new joist that is shallower than the damaged joist so installation is easier. Consider double and triple joists. If the damaged joist is multi-span, the new joist only needs to go across the span(s) where the damage occurs.
- A single damaged joist can sometimes be trimmed off of adjacent undamaged joists (run a calculation within the SmartFrame software).

### WEB DAMAGE

- Web damage becomes more critical the nearer a support. Web damage is less critical near mid-span.
- Web holes can be too big to repair. A flange-to-flange rectangular hole longer than 450 mm located at mid-span probably warrants a new joist. A 150 mm round hole located right by a support probably warrants a new

joist. Consult SmartJoist and SmartLVL tables to find an acceptable new joist that is shallower than the damaged joist so installation is easier. Consider double and triple joists. If the damaged joist is multi-span, the new joist only needs to go across the span(s) where the damage occurs.

- A single damaged joist can sometimes be trimmed off of adjacent undamaged joists (run a calculation within the SmartFrame software)
- Damage that could be confidently repaired in a single, isolated joist, might be judged too severe to repair if several, adjacent joists are involved
- If several small holes violate the 2x diameter proximity rule, but would fit inside a single acceptable hole, then the group of small holes is OK
- Hole repairs generally require a reinforcement that covers the full depth of the web and extends at least 300 mm past each side of the hole.

### DAMAGE REPORT INFORMATION REQUIRED

1. In order to design a repair, the SmartFrame engineer will have to know all of the design information that is required to run SmartFrame software.
2. Provide a sketch of the damage showing its size, shape and location on the joist.
3. Indicate whether a pipe, duct, conduit, etc. must remain and be accommodated.
4. Indicate how many adjacent joists are affected in each case.

## FIELD REPAIRS TO DAMAGED SmartJoist WEBS

The SmartFrame system now includes the WebFix® (web reinforcement) developed to be a rapid "repair" to webs where penetrations have been placed at inappropriate locations, penetrations too large or other web damage which diminishes the strength of the member. This repair system is unique to SmartJoist applications.

Tilling Timber is the SOLE Australian distributor of this PATENTED system, which in most cases can be fixed around services that have been installed through the web penetrations.

The WebFix® does need to be designed into each situation by SmartFrame engineers and can ONLY be purchased from Tilling offices after the structural design is completed.

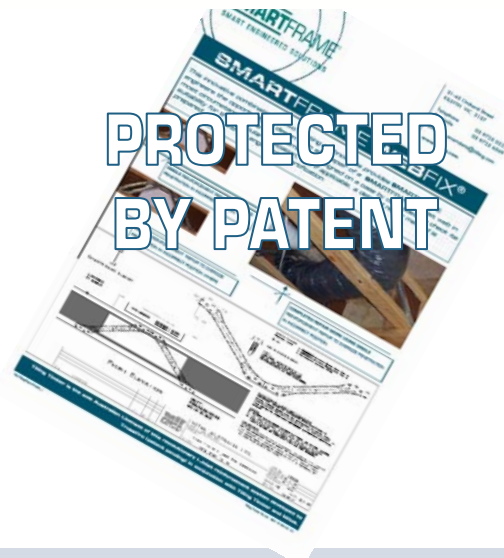

# TYPICAL SmartJoist FLOOR FRAMING

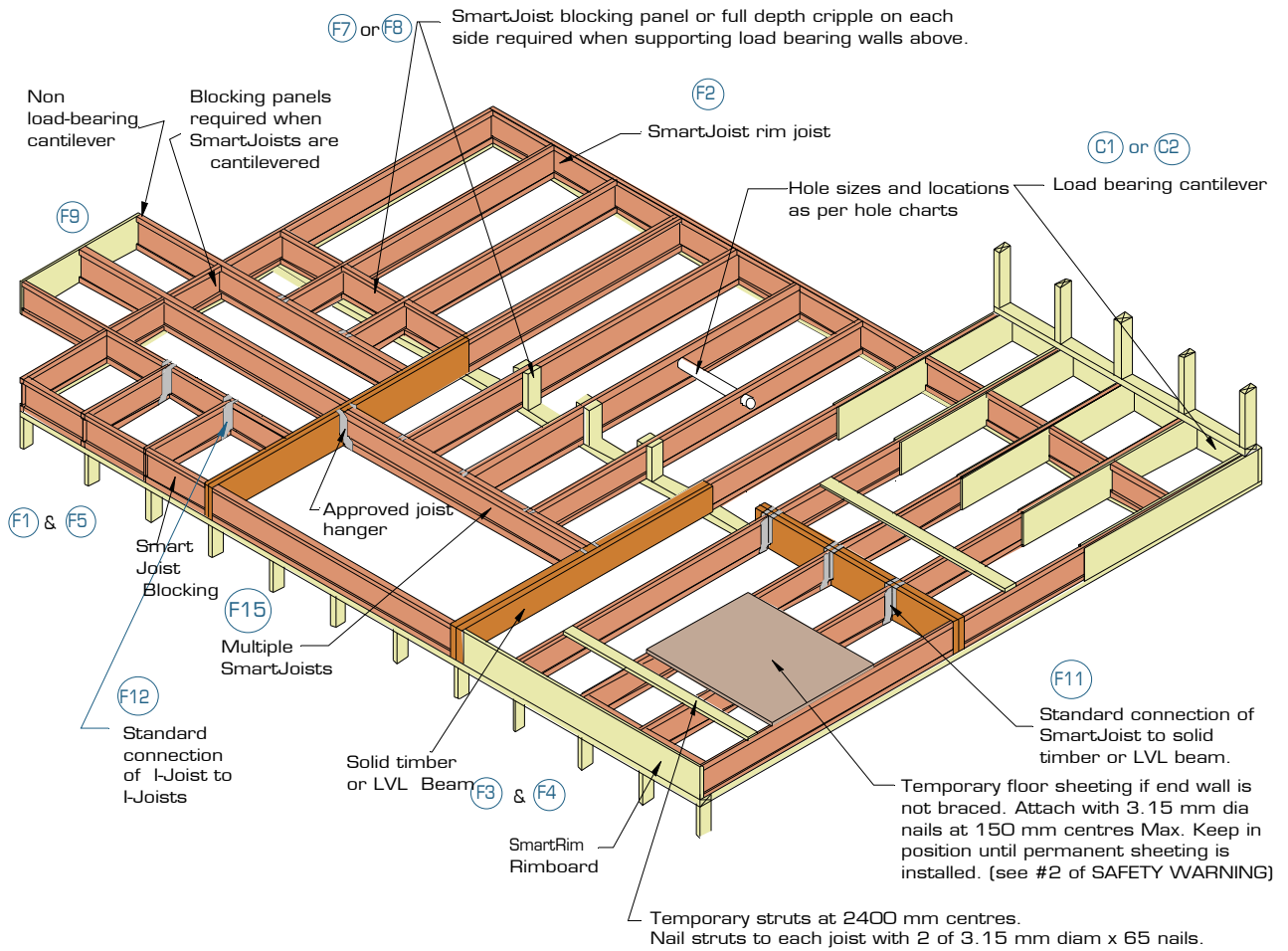

# TYPICAL SmartJoist FLOOR CONSTRUCTION DETAILS

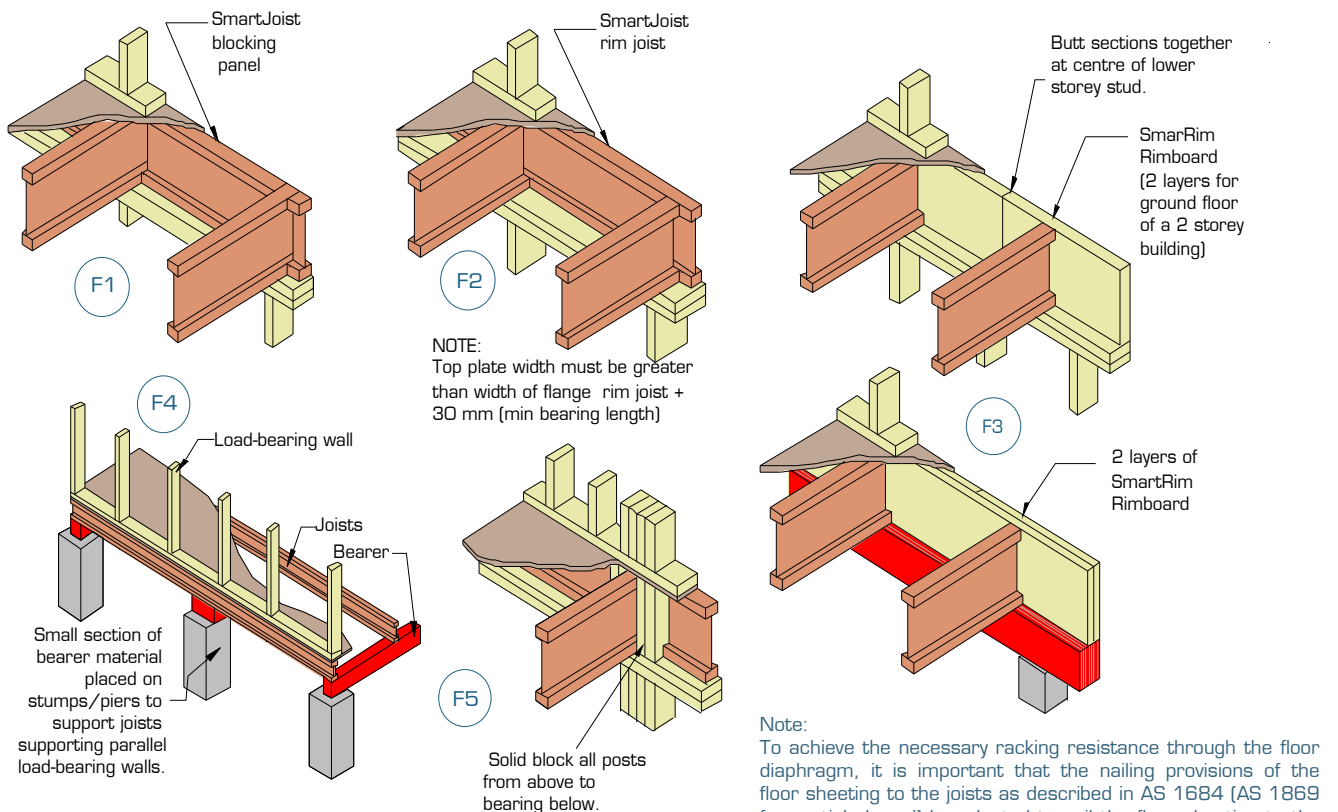

## CONCENTRATED ROOF LOADS

# TYPICAL SmartJoist FLOOR CONSTRUCTION DETAILS (Cont'd)

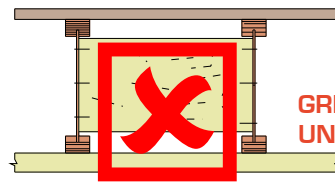
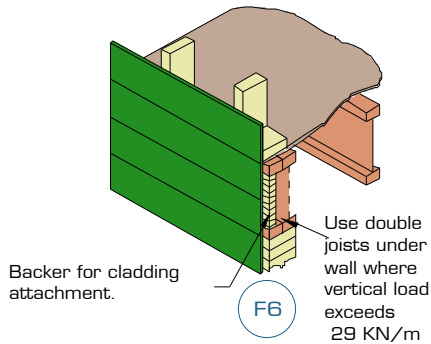

**WARNING - CORRECT BLOCKING FOR SmartJoists**

**GREEN TIMBER SHALL NOT BE USED UNDER ANY CIRCUMSTANCE.**

All blocking shall be carried out as per details F1-F3, with blocking to extend to both flanges and skew nailed with 3.15  $\Phi$  x 65 nails, one each side of top and bottom flange.

## INTERIOR LOAD BEARING AND BRACING WALLS

SmartJoist shall be designed to support load bearing wall above when not stacked over wall below.

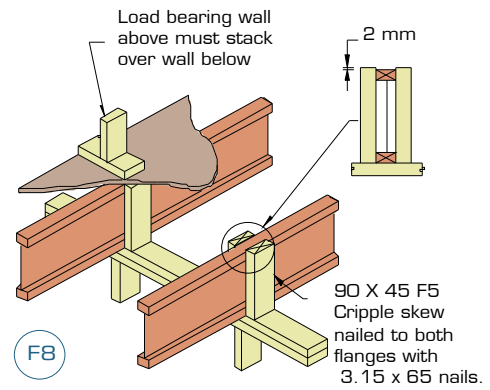
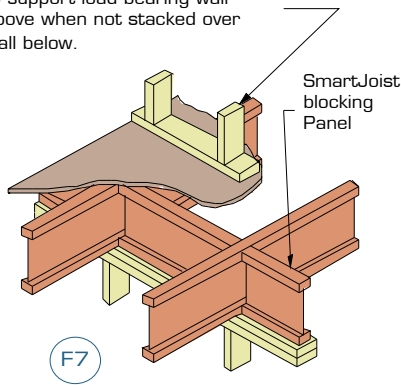

## NON LOAD-BEARING CANTILEVER DETAILS (BALCONIES)

Example cantilever spans and minimum back spans for this detail are shown in the table on the next page

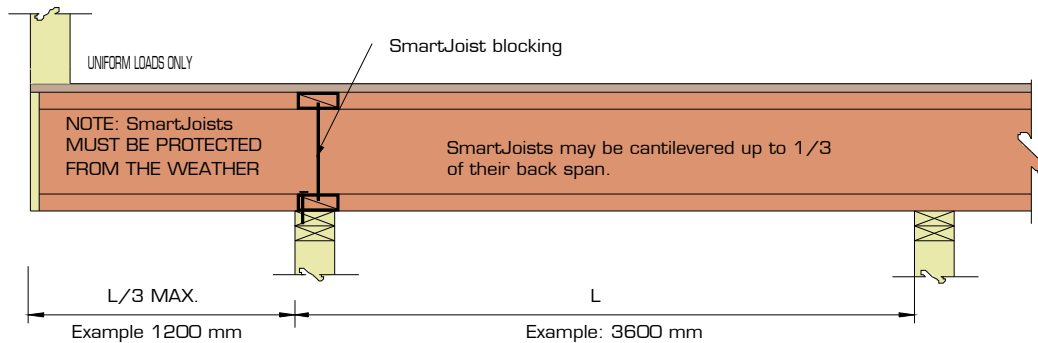
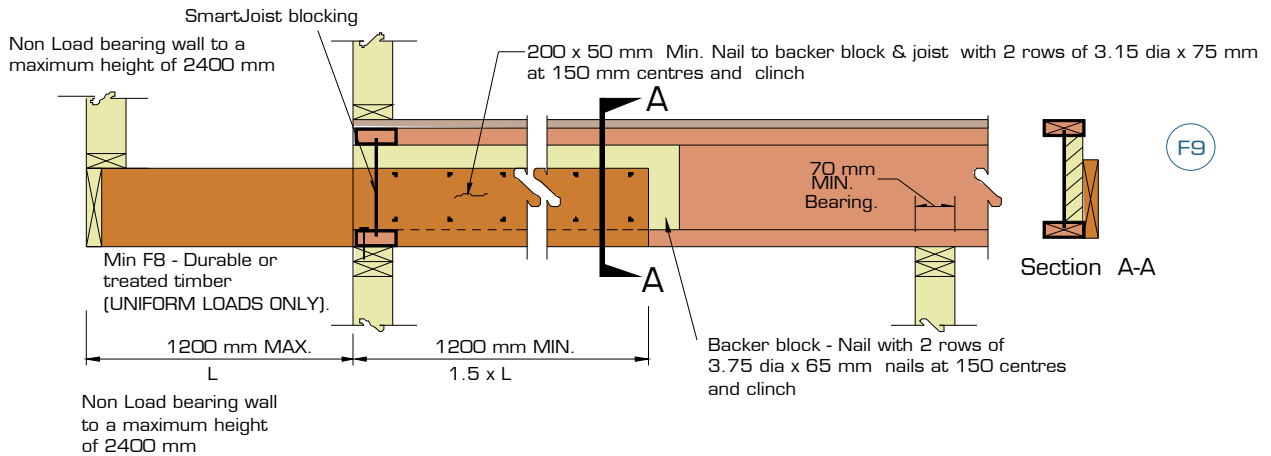

**FOR CANTILEVERS SUPPORTING LOAD BEARING WALLS, SEE DETAILS C1 or C2.**

# CANTILEVERED BALCONIES as per detail F9

Loadings: Permanent Loading G: self weight + 40 kg/m<sup>2</sup> + 0.6 kPa of live load permanently applied, live load Q: 2.0 kPa or 1.8 kN point live load, 1.5 kN/m acting at end of cantilever

## Balcony Cantilevers - Maximum cantilever and minimum back span (m)

Joist spacing (mm)	300		400		450		600	
	Cantilever	Back span	Cantilever	Back span	Cantilever	Back span	Cantilever	Back span
<b>H3 SmartFrame LVL 15</b>								
150 x 42	1.0	1.5	1.0	1.5	1.0	1.5	0.9	1.4
170 x 42	1.2	1.8	1.1	1.7	1.1	1.7	1.1	1.7
200 x 42	1.4	2.1	1.3	2.0	1.3	2.0	1.3	2.0
240 x 42	1.7	2.6	1.6	2.4	1.6	2.4	1.5	2.3
300 x 42	2.1	3.2	2.0	3.0	2.0	3.0	1.9	2.9
<b>H3 MGP 10</b>								
140 x 45	0.7	1.1	0.7	1.1	0.7	1.1	0.7	1.1
190 x 45	1.1	1.7	1.1	1.7	1.1	1.7	1.1	1.7
240 x 45	1.5	2.3	1.4	2.1	1.4	2.1	1.4	2.1

## BACKER and FILLER BLOCKS

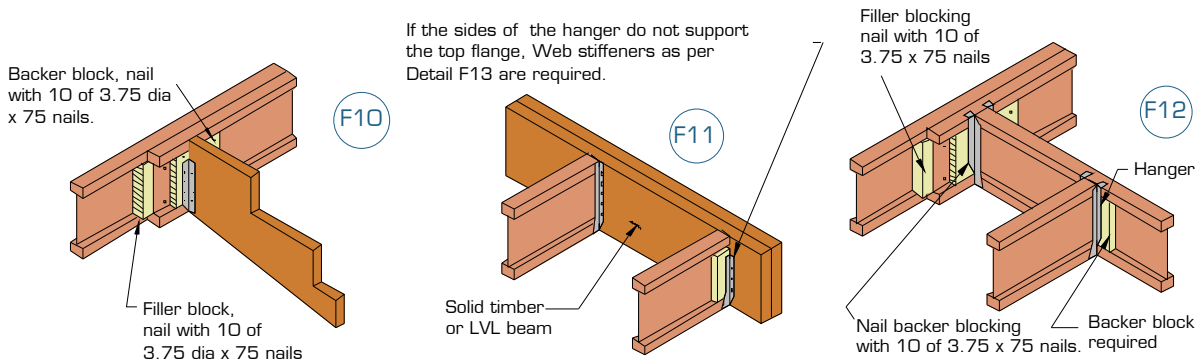

### FILLER BLOCKS AND WEB STIFFENERS

SmartJoist code	Recommended filler block	Web stiffener material	
		stiffener	nails
SJ20044	120x35	15x60 mm ply	4-3.15x65
SJ24040	140x35	15x60 mm ply	4-3.15x65
SJ24051	140x45	19x60 mm ply	4-3.15x65
SJ24070	150x58 LVL	2/15x60 mm ply	4-3.15x65
SJ24090	2/140x45	2/19x60 mm ply	5-3.15x65
SJ30040	190x35	15x60 mm ply	4-3.15x65
SL30051	190x45	19x60 mm ply	4-3.15x65
SJ30070	150x58 LVL	2/15x60 mm ply	4-3.15x65
SJ30090	2/190x45	2/19x60 mm ply	5-3.15x65
SJ36058	250x50	2/12x60 mm ply	5-3.15x65
SJ36090	2/240x45	2/19x60 mm ply	5-3.15x65
SJ40090	2/240x45	2/ply	5-3.15x65

### WEB STIFFENERS

#### NOTES :

- Use plywood sheathing for web stiffener with face grain parallel to long axis of the stiffener.
- Filler blocks noted are for the general requirements of the details within this design guide.
- Leave 3 mm gap between top of filler blocks and bottom of top flange.

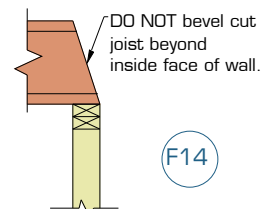
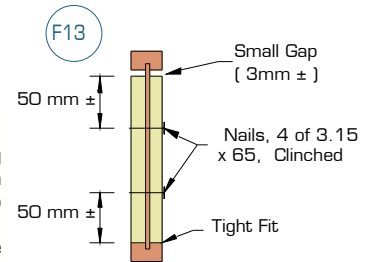

NOTE: SmartJoist blocking or timber X-bracing required at bearing for lateral support.

### DOUBLE SmartJoists

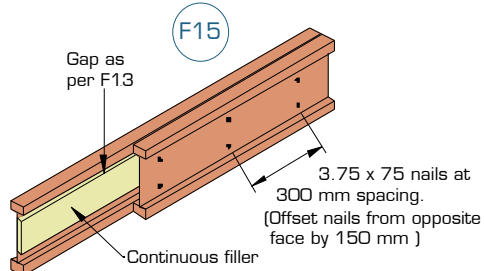

- Support back of web during nailing to prevent damage to web/flange connection
- Filler block is required full length of joist
- Nail Joists together with two rows of 3.75 φ x 75 nails on each side of double joist at 300 mm centres (Clinch if possible). A total of 4 nails per 300 mm is required. If nails can be clinched, only 2 nails per 300 mm is required.

# FASTENER SPACING

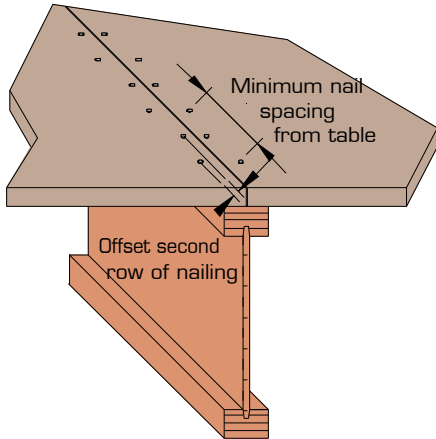

Minimum single row nail spacing into SmartJoist flanges

nail size	SmartJoist flange width				
	40 mm	44 mm	51 mm flange	58-70 mm	90 mm flange
2.8 x 65	70	65	50	50	50
3.15 x 65	100	90	75	75	75
3.15 x 75	100	90	75	75	75
3.75 x 75	130	115	100	100	100
4.5 x 100	NA <sup>1</sup>	NA <sup>1</sup>	NA <sup>1</sup>	NA <sup>1</sup>	100

**NOTES:**

1. Nailing of bottom plate at 100 mm centres through floor sheathing and into top flange is permitted.
2. Minimum nail spacing is shown above, maximum nail spacing is 300 mm centres.
3. Tighter effective nail spacing may be obtained by offsetting nail rows a minimum of 12 mm and maintaining a 10 mm minimum edge distance.

## LIMITED END NOTCHING AT SUPPORTS

The cutting of notches in the ends of joists may reduce the allowable end reactions of the SmartJoists

The amended end reaction capacities of SmartJoists with a 12 mm notch are as follows:

- Without web stiffeners - 80% of allowable end reaction
- With added web stiffeners (as per detail F13) - Full end reaction capacity.

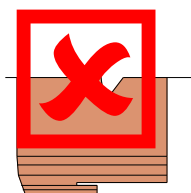
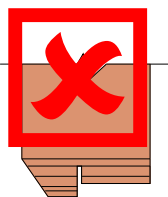

**DO NOT OVER CUT FLANGES. SUBSTANTIAL REDUCTIONS IN CAPACITY MAY OCCUR IF FLANGES ARE OVER CUT.**

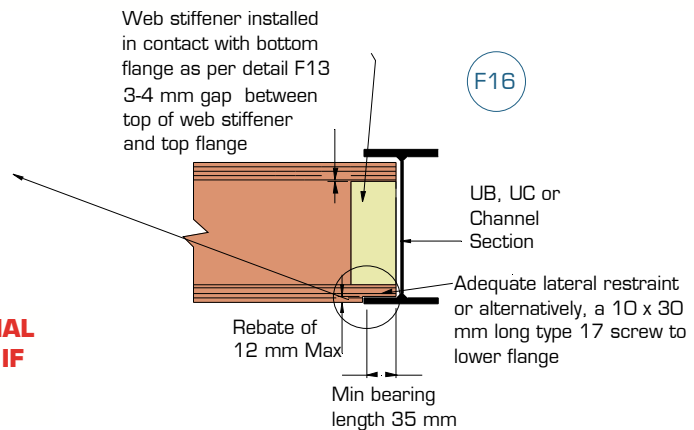

To maintain the end reaction capacities above, end flange notching is strictly limited to:

1. Notch depths NOT greater than 12 mm
2. Notches cleanly cut - NO over cutting
3. Notch length not to exceed more than 5 mm past the support.

## EXAMPLE FIXING OF SmartJoists TO STEEL BEAMS

**TOP MOUNT HANGER**

F17

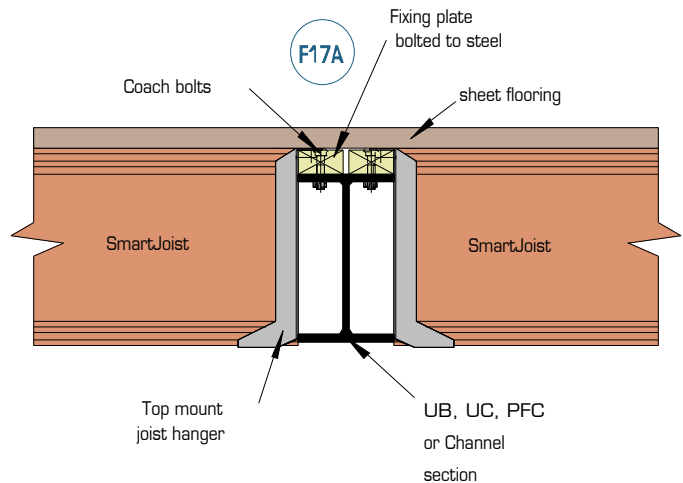
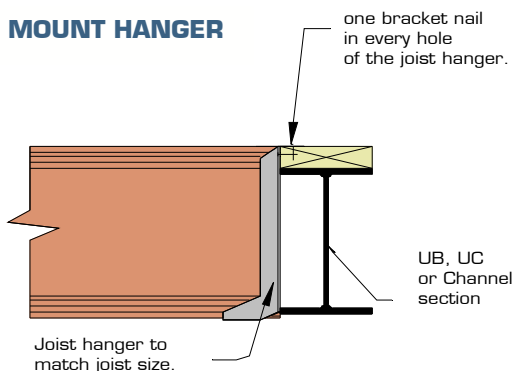

# EXAMPLE FIXING OF SmartJoists TO STEEL BEAMS (Cont'd)

## LOWER FLANGE BEARING

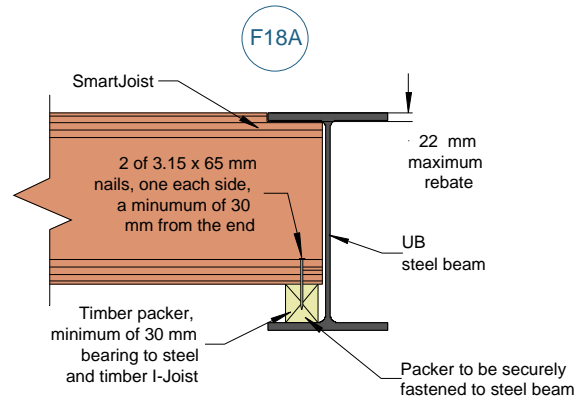
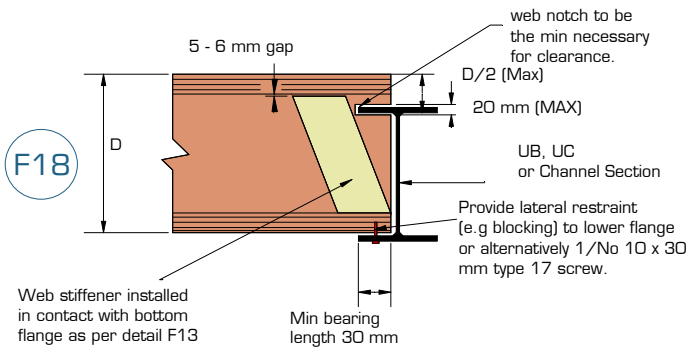

## FACE MOUNT HANGER

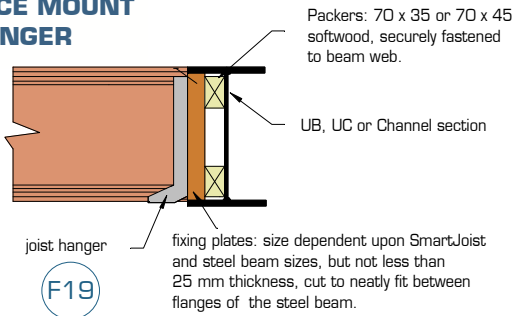

## EXAMPLE FIXING OF SmartJoists TO BRICK OR MASONRY WALLS

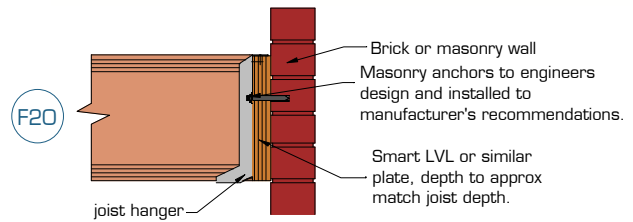

## TIE DOWN (BRACING WALL) DETAILS

The tie-down needs of the structure are related to the applied wind loads. Reference should be made to AS 1684 for further guidance on this issue. The general details relating to the tie-down provisions of solid end section timber may be adopted for SmartJoists, except that under NO circumstances is it permitted to bolt through either the top or bottom flange, except when the joist is fully supported upon a wall plate or similar as shown below.

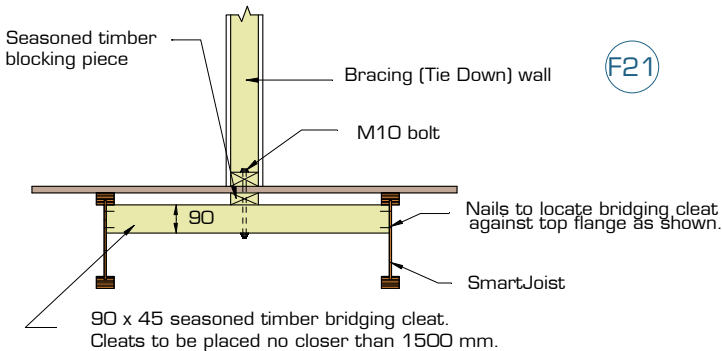

NOTE : CHARACTERISTIC UPLIFT CAPACITY 11.9 kN

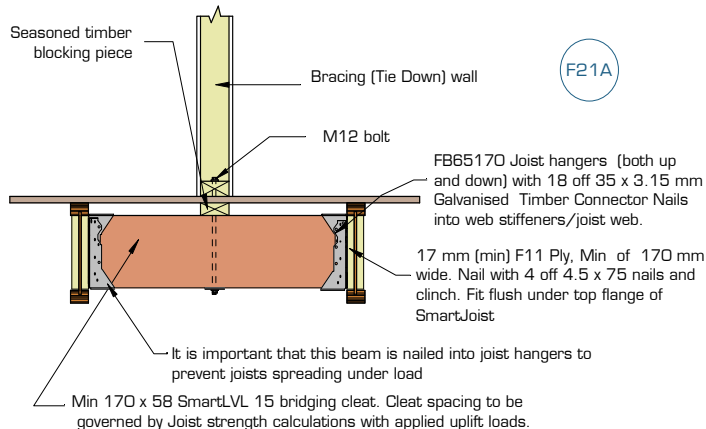

NOTE: MAX force transfer of system 30.0 kN  
(It is essential that SmartJoist is analysed for these extreme loads)

**DO NOT DRILL THROUGH EITHER FLANGE OF SmartJoists unless they are fully supported on wall plate or similar**

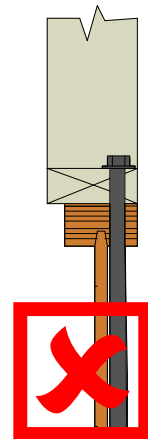

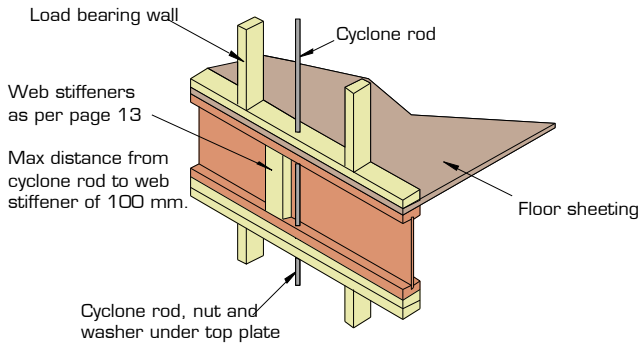

### CYCLONE STRAP CAPACITIES

Where the strap ends of the cyclone strap are wrapped around the wall plate or other timber member and are fixed with 4 of 3.15 Ø x 35 nails, the design capacity  $\phi N_f$  of 15.3 kN is applicable, regardless of the timber joint group. Tests have proven that bending the legs of cyclone straps around the timber increases the ultimate load capacity.

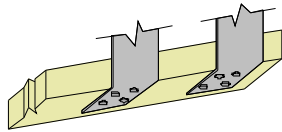

### CYCLONE ROD TIE DOWN FOR CANTILEVERED SmartJoist FLOORS

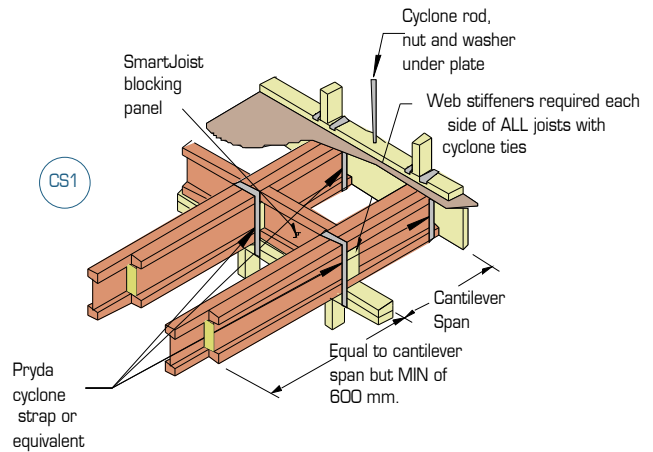

While double joists shown in the above diagram, it is only necessary when loads exceed the capacities of single joist cantilevers.

### JOIST/BEAM CONNECTIONS SUPPORTING OFFSET LOAD BEARING WALLS

Modern building designs frequently call for the upper storey of a two storey dwelling to be set back from the lower wall to allow sufficient light access to all areas of the building. Provided that the SmartJoists have been designed to support this offset load, no special provisions need to be made for their support EXCEPT in the following support conditions:

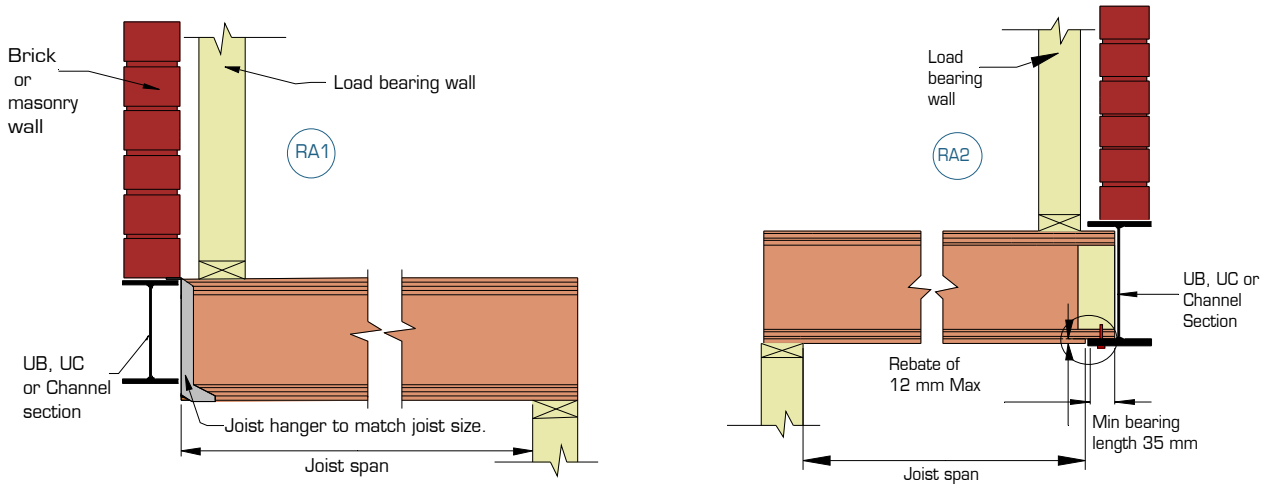

### Maximum Roof Area Supported (m<sup>2</sup>)

- based upon worst case of 40 mm flange width (conservative for wider flanged joists)

Joist spacing (mm)	Joist supported on joist hanger RA1								Lower flange bearing RA2							
	300	400	450	600	300	400	450	600	300	400	450	600	300	400	450	600
Joist span (mm)	Sheet				Tile				Sheet				Tile			
3500	21.7	15.0	12.8	8.2	9.6	6.7	5.7	3.6	6.9	6.4	6.2	5.3	3.1	2.9	2.8	2.4
4000	21.1	14.5	12.3	6.9	9.4	6.4	5.5	3.1	6.7	6.2	6.0	4.6	3.0	2.8	2.7	2.0
4500	20.5	13.9	11.7	5.7	9.1	6.2	5.2	2.5	6.6	6.0	5.7	3.9	2.9	2.7	2.5	1.7
5000	20.0	13.4	10.4	4.4	8.9	5.9	4.6	2.0	6.4	5.8	5.1	3.1	2.9	2.6	2.3	1.4
5500	19.4	12.1	9.1	3.2	8.6	5.4	4.1	1.4	6.3	5.3	4.6	2.4	2.8	2.4	2.0	1.1

# SUPPORT FOR CONCENTRATED LOADS - JOIST/BEAM CONNECTIONS SUPPORTING OFFSET LOAD BEARING WALLS

RA3

Concentrated loads from any source such as girder trusses MUST be transferred through the floor space WITHOUT adding extra vertical loads to the ends of the SmartJoist at its bearing support.

One example of transferring these loads is the use of inclined timber struts as shown in the detail opposite. Struts must be a tight fit and at a minimum angle of 60° to the horizontal

- Skew nail 2 of 3.15 x 75 mm nails through to lower plate
- 70 x 35 F5 nailed to underside of top flange of adjacent joists with 3.15 x 60 nails
- 90 x 45 F5 strut under concentrated load. Number of struts to match number of members in jamb stud or post.

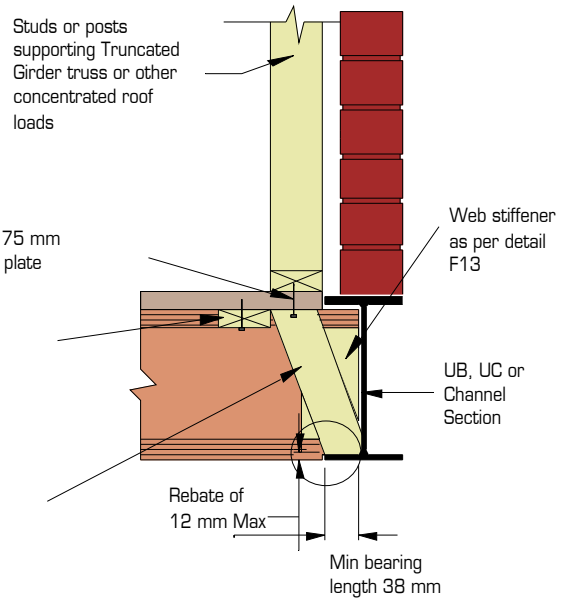

## BEAMS SUPPORTING SmartJoists - MULTIPLE MEMBER LAMINATIONS

Vertical laminations may be achieved by adopting the procedures described in clause 2.3 of AS1684, however these procedures should be considered as the minimum requirements to achieve the desired effect.

Experience with SmartLVL beams indicates that this degree of fixing may not satisfactorily prevent cupping of individual components as a result of the ingress of moisture between laminates during construction. The suggested method of vertical lamination below provides a greater level of fixity between individual components, and with the use of an elastomeric adhesive, also prevents moisture penetration between the laminates.

### MULTIPLE MEMBER LAMINATING OF TOP LOADED BEAMS (Symmetrical loading)

The edges of the individual sections must be carefully aligned to each other so that the composite beam is flat, allowing the applied loads to be equally shared.

- Depths up to and including 300 mm: 2 rows of nails as shown above at 300 mm centre
- Depths in excess of 300 mm: 3 rows of nails as shown above at 300 mm centres

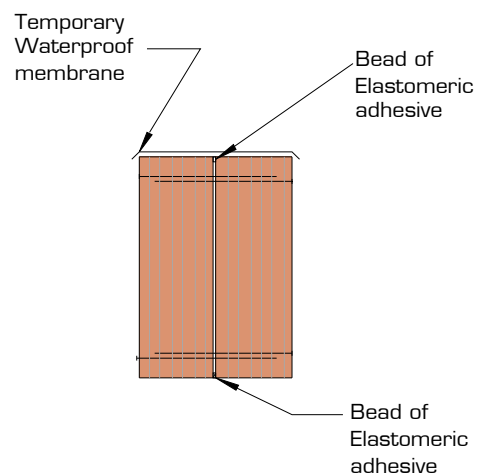
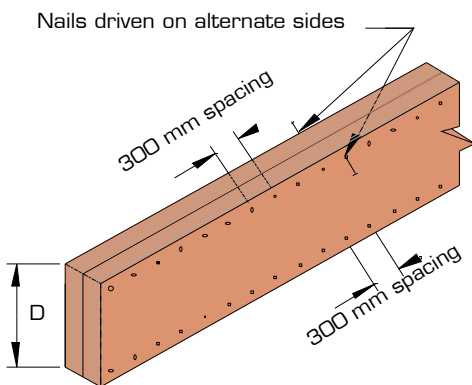

# MULTIPLE MEMBER LAMINATING OF SIDE LOADED BEAMS (Non- symmetrical loading)

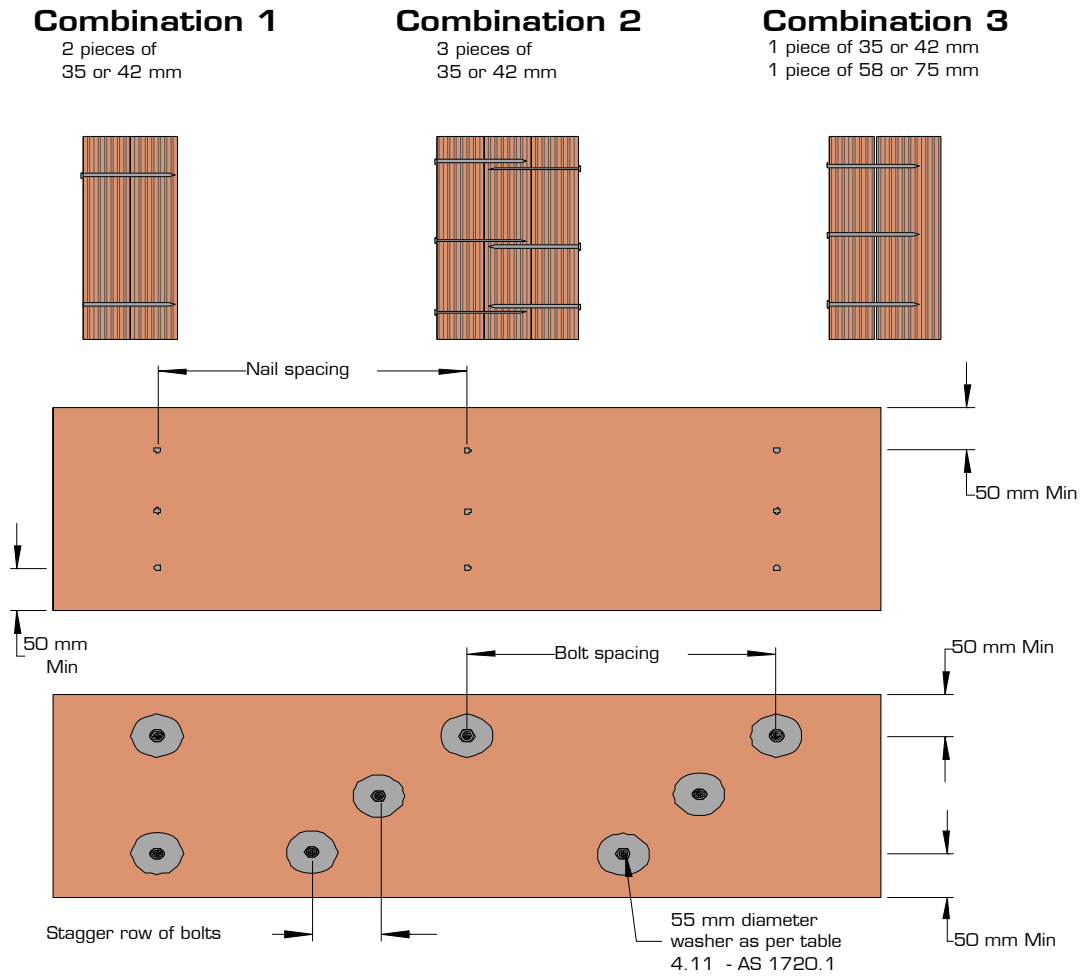

## MAXIMUM FLOOR LOAD WIDTH SUPPORTED BY EITHER OUTSIDE MEMBER (mm)

Combination (see details above)	3.75Φ x 90 mm nails		12 mm Φ bolts	
	2 rows at 300 ctrs	3 rows at 300 ctrs	2 rows at 600 ctrs	2 rows at 300 ctrs
Combination 1	3400	5100	7500	15000
Combination 2	2900	4000	5600	11000
Combination 3	2900	4000	4500	11000

**Notes:**

1. Table values are for 40 kg/m<sup>2</sup> floors.
2. The table values for nails may be doubled for nails at 150 mm centres, and tripled for nails at 100 mm centres
3. The nail schedules shown apply to both sides of a three (3) piece beam
4. Bolts are to be grade 4.6 commercial bolts conforming to AS 1111. Bolt holes are to be a maximum of 13 mm diameter and are to be located NOT less than 50 mm from either edge.
5. All bolts shall be fitted with a washer at each end, of a size NOT less than that given in AS 1720.1 table 4.11.

### HOW TO USE THE MAXIMUM UNIFORM SIDE LOAD TABLE

Example: see diagram opposite

Beam of 2 SmartLVL loaded on both side (Combination 1)  
 FLW 1 = 2800 mm, FLW 2 = 2300 mm  
 Total FLW = 2800 + 2300 = 5100 mm.

1. Use SmartFrame software or SmartLVL safe load tables to size the two member section to support the FLW of 5100 mm.
2. Choose the larger of the side FLW's carried by the beam, in this case 2800 mm.
3. Enter the table at the "Combination 1" row and scan across to a table value greater than 2800 mm. The first value in the row at 3600 mm is greater than the 2800 mm required.
4. Thus adopt 2 rows of 3.75Φ x 90 mm nails at 300 mm centres

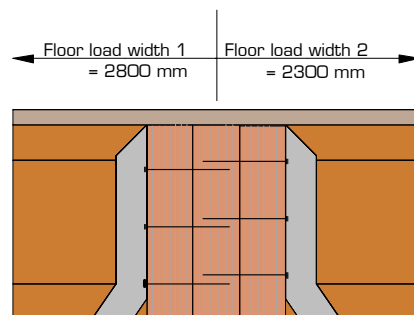

# BRICK LEDGE CANTILEVERS CONSTRUCTION DETAILS

Cantilevered SmartJoists as "brick ledge cantilevers" (Max of 160 mm cantilever) to suit upper storey clad frames DO NOT usually require any special modification (other than the necessary timber or ply/LVL closure member attached to the outer edge as shown in details C1 or C2). The exceptions to this are where concentrated floor loads (e.g. truncated girders, jamb studs) are supported on an

Individual cantilevered joist such that the concentrated roof load area supported exceeds that as shown below for an un-reinforced SmartJoist.

Individual joists may be reinforced, if required, as per details F23 or F24 to support a roof load area (measured in square metres) as shown below.

Joist spacing	Un-reinforced SmartJoist						Web Filler (F23)						Reinforcing one side (F24)					
	Sheet Roof			Tiled Roof			Sheet Roof			Tiled Roof			Sheet Roof			Tiled Roof		
	300	450	600	300	450	600	300	450	600	300	450	600	300	450	600	300	450	600
SmartJoist	Roof area supported (m <sup>2</sup> )																	
SJ20044	8.8	7.1	5.4	5.1	4.2	3.2	12.2	10.5	8.8	7.2	6.2	5.2	10.2	8.6	6.9	6.0	5.0	4.0
SJ24040	9.7	8.0	6.3	5.7	4.7	3.7	13.1	11.4	9.7	7.7	6.7	5.7	11.1	9.4	7.7	6.5	5.5	4.5
SJ24051	10.6	8.6	6.9	6.0	5.0	4.1	13.7	12.0	10.3	8.0	7.0	6.1	11.8	10.1	8.4	6.9	5.9	4.9
SJ24070	14.2	13.2	12.2	8.3	7.6	6.9	15.6	14.5	13.3	9.1	8.5	7.8	17.6	16.4	15.2	10.3	9.6	8.9
SJ24090	17.9	16.2	14.5	10.5	9.5	8.5	21.3	19.6	17.9	12.5	11.5	10.5	19.3	17.6	15.9	11.3	10.3	9.3
SJ30040	9.6	8.0	6.3	5.6	4.7	3.7	13.1	11.4	9.7	7.6	6.7	5.7	11.1	9.4	7.7	6.5	5.5	4.5
SJ30051	10.3	8.6	6.9	6.0	5.0	4.0	13.7	12.0	10.3	8.0	7.0	6.0	13.6	12.3	11.2	8.0	7.2	6.6
SJ30070	13.7	12.4	11.2	8.0	7.3	6.6	18.9	17.6	16.4	11.1	10.3	9.6	17.2	15.8	14.6	10.0	9.3	8.6
SJ30090	17.8	16.2	14.5	10.4	9.5	8.5	21.3	19.6	17.9	12.4	11.5	10.5	19.3	17.6	15.9	11.3	10.3	9.3
SJ36058	12.9	11.2	9.5	7.5	6.5	5.5	16.3	14.6	12.9	9.5	8.5	7.6	14.3	12.6	10.9	8.4	7.4	6.4
SJ36090	17.8	16.1	14.4	10.4	9.4	8.5	21.2	19.6	17.9	12.4	11.4	10.5	19.3	17.6	15.9	11.3	10.3	9.3
SJ40090	17.8	16.1	14.4	10.4	9.4	8.4	21.2	19.5	17.9	12.4	11.4	10.5	19.3	17.6	15.9	11.3	10.3	9.3

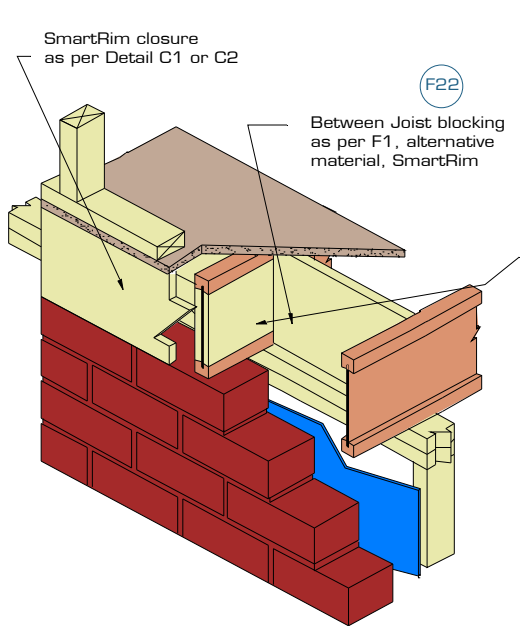

**TRIMMER JOISTS WHERE MAIN JOISTS RUN PARALLEL TO BRICK LEDGE CANTILEVER WALL.**

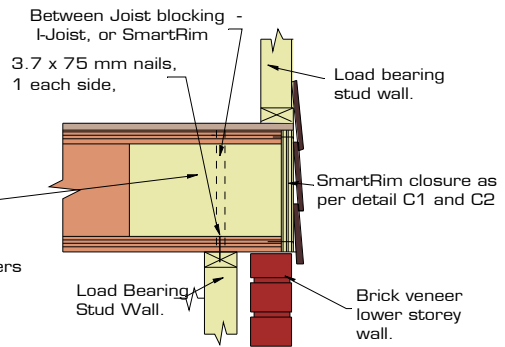
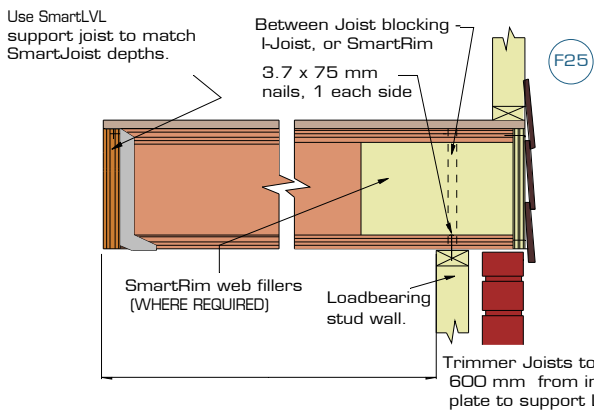

**REINFORCING GUIDELINES (a) USING WEB FILLERS**

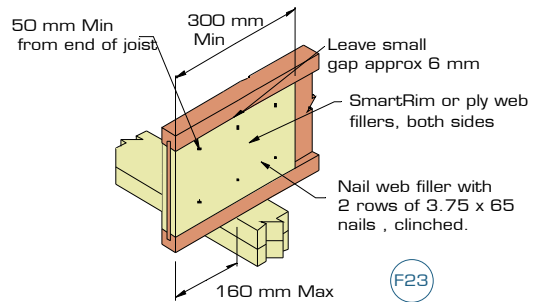

**(b) USING REINFORCING (one side)**

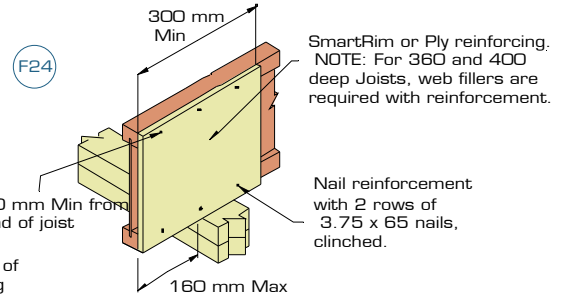

## RAFTER CUTS OF SmartJoists

SmartJoists can be "rafter cut" but only within the limitation shown below.

Rafter cuts are limited to:

- 1) 115 mm MINIMUM end height
- 2) MINIMUM Roof Slopes of 1 in 2 (approximately 26.5°),  
and
- 3) Must be blocked at the end to prevent rotation of the joist.

Joists without reinforcement are limited to design shear and end reactions up to 6.5 kN Ply reinforcement can be added to joists with rafter cuts to increase the shear and end reaction capacity of the joist. The detail below shows the proper installation of the reinforcement. With the reinforcement added, the end reaction and shear capacity increase to 12.7 kN Duration of load increases are permitted as per AS1720.1.

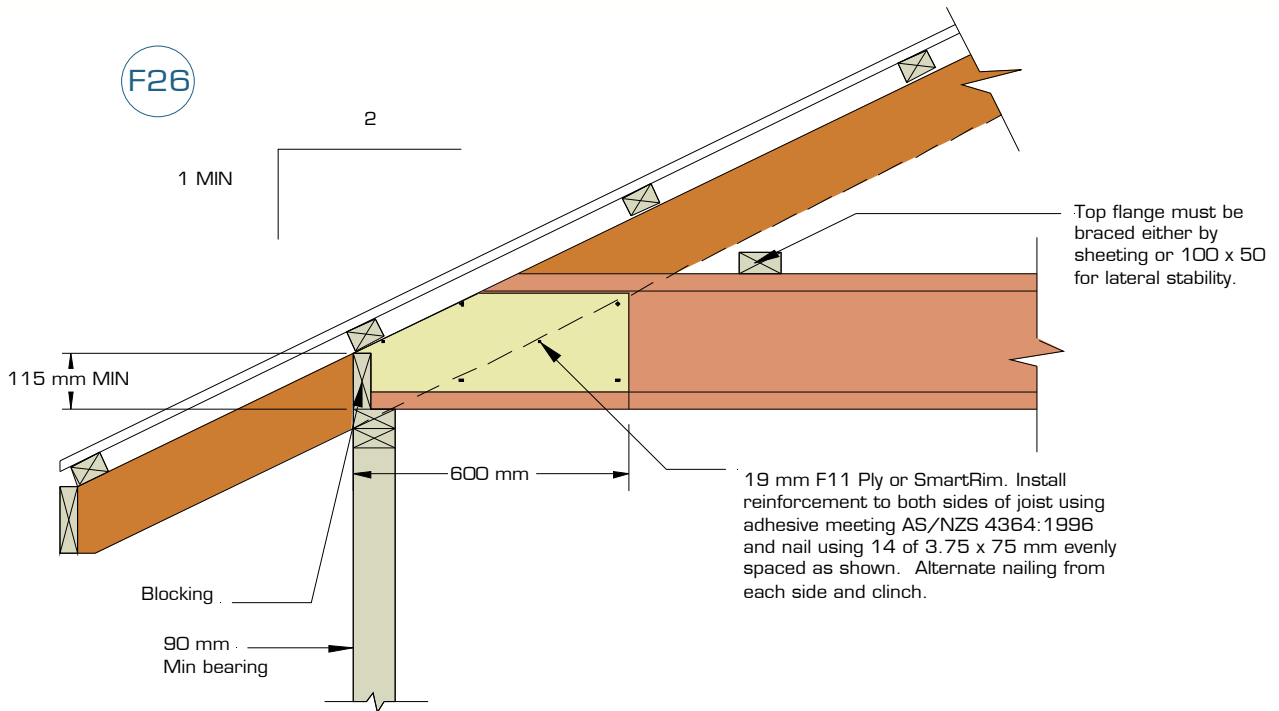

## OBLIQUE CONNECTION OPTIONS

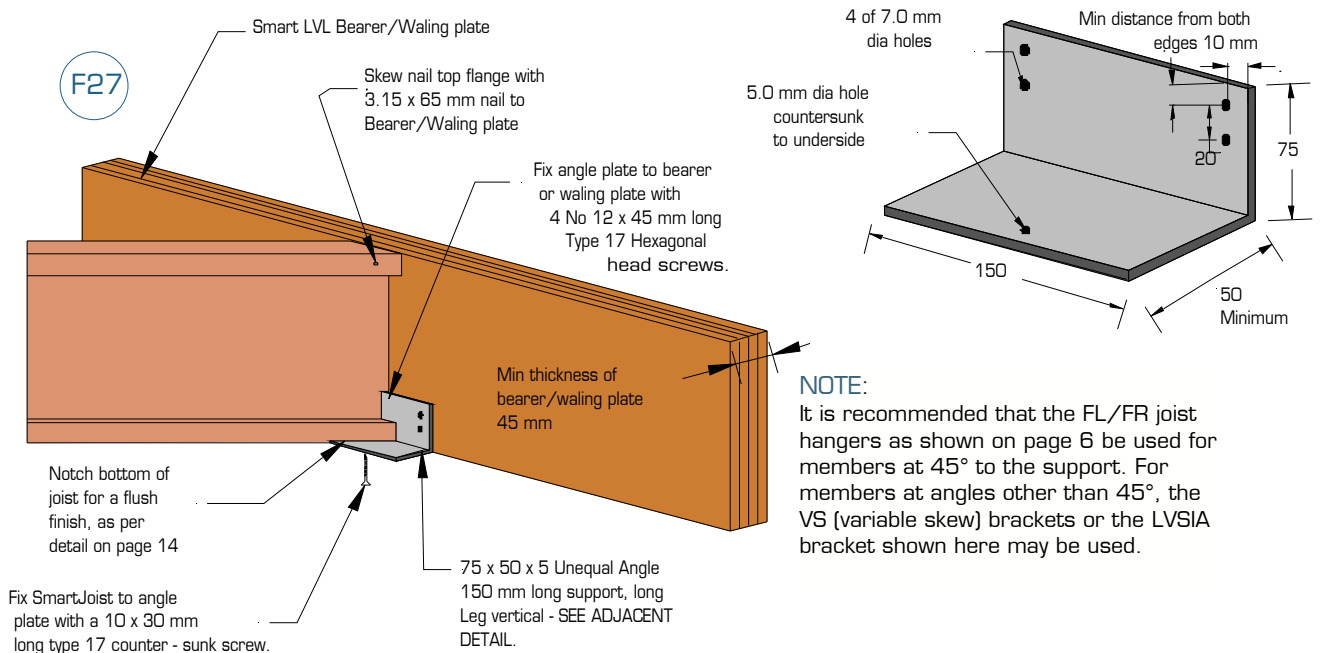

## SmartJoist HOLE CHARTS

**DON'T  
MAKE HOLES  
WITH HAMMER  
OTHER THAN  
PRE-PUNCHED  
KNOCKOUTS**

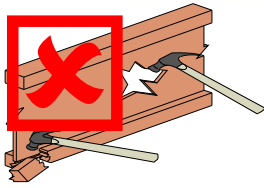

**DON'T  
HAMMER ON  
FLANGES AND  
DAMAGE  
JOINT**

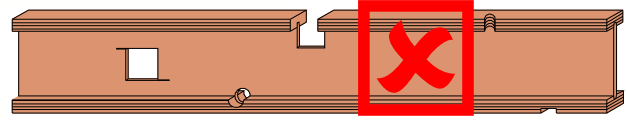

**DO NOT CUT OR NOTCH FLANGES  
DO NOT OVER CUT HOLES IN WEB**

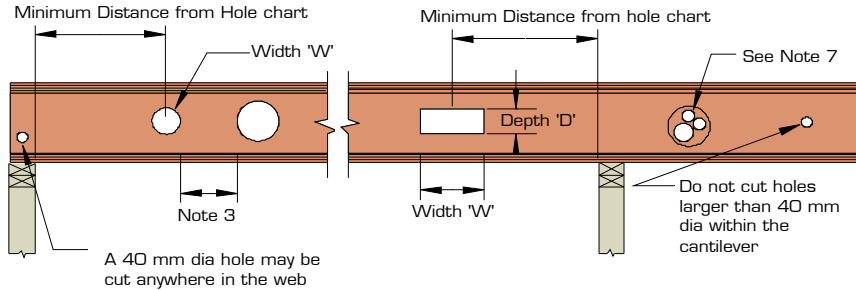

*Note: The most accurate method to design the allowable web penetration size and distance from support for SmartJoists is to use the SmartFrame software. The table below will give conservative results in some instances. Also, advice on hole size and location may be obtained by contacting the SmartData Customer Helpline on 1300 668 690 or at smartdata@tilling.com.au.*

Joist Code	Joist span (mm)	Joist spacing (mm)	Circular Holes							Rectangular Holes				
			Hole Diameter/Square Hole Width (mm)							Depth x Width (mm)				
			75	100	125	150	175	200	225	250	125x150	150x300	175x350	200x400
Minimum distance from any support to the centre of the hole (mm)														
SJ20044	3000	600	300	400	-	-	-	-	-	-	-	-	-	
	3500	600	300	700	-	-	-	-	-	-	-	-	-	
SJ24040	3000	600	300	300	300	900	-	-	-	-	1350	1500	-	-
	3500	600	300	300	300	1200	-	-	-	-	1700	1750	-	-
SJ24051	3500	600	300	300	300	1200	-	-	-	-	1600	1750	-	-
	4000	600	300	300	600	1500	-	-	-	-	1950	2000	-	-
SJ24070	3500	600	300	300	300	1100	-	-	-	-	1450	1750	-	-
	4000	600	300	300	300	1400	-	-	-	-	1800	2000	-	-
	4500	600	300	300	600	1600	-	-	-	-	2250	2250	-	-
SJ24090	4000	600	300	300	300	1300	-	-	-	-	1650	1900	-	-
	4500	600	300	300	300	1550	-	-	-	-	1950	2250	-	-
	4700	600	300	300	400	1600	-	-	-	-	2150	2350	-	-
SJ30040	4000	600	300	300	300	300	600	1300	-	-	1600	2000	2000	2000
	4500	600	300	300	300	300	800	1550	-	-	1950	2250	2250	-
SJ30051	4000	600	300	300	300	300	500	1250	-	-	1400	1900	2000	2000
	4500	600	300	300	300	300	650	1500	-	-	1750	2150	2250	2250
	4700	600	300	300	300	300	800	1600	-	-	1900	2350	2350	-
SJ30070	4500	600	300	300	300	300	450	1400	-	-	1550	2100	2200	2250
	5000	600	300	300	300	300	700	1650	-	-	2000	2400	2500	2500
SJ30090	5000	600	300	300	300	300	400	1500	-	-	1600	2350	2400	2450
	5300	600	300	300	300	350	600	1650	-	-	1850	2500	2600	2650
SJ36058	5000	600	300	300	300	300	350	400	1100	1700	400	2000	2350	2400
	5500	600	300	300	300	350	400	600	1250	1950	700	2250	2600	2750
SJ36090	5500	600	300	300	300	300	300	300	700	1600	400	1950	2450	2650
	5800	600	300	300	300	300	300	300	850	1750	700	2150	2650	-
SJ40090	6000	600	300	300	300	300	300	300	300	800	400	550	2100	2650
	6300	600	300	300	300	300	300	300	400	1000	700	950	2400	2800

**Notes:**

1. The hole chart is generated on a maximum floor dead load of 40 kg/m with no wall or roof loads. It therefore does not apply for joists supporting either parallel or perpendicular load bearing walls. These scenarios can be analysed by using the appropriate model within the SmartFrame software. Help can be obtained by contacting the SmartFrame Customer Helpline on 1300 668 690 or at smartdata@tilling.com.au
2. Hole locations are suitable for joist spacings up to 600 mm centres. Holes may be permitted closer to supports for some member when spacings of 450 or 300 mm are used
3. The clear distance between holes must equal or exceed twice the diameter of the largest hole, or twice the longest side of a rectangular hole and no more than 3 holes in excess of 75 mm are allowed in any span
4. Do not cut or damage flanges under any circumstances
5. Except as noted in 1 and 2 above, a 40 mm hole at a minimum of 450 mm centres is allowed to be drilled anywhere in the web EXCEPT in cantilevered spans
6. If possible, holes in web should be positioned mid height, minimum edge clearance from any flange is 6 mm
7. A group of round holes at approximately the same location shall be permitted if they meet the requirements for a single round hole circumscribed around them.

# OPENINGS WITHIN SmartFrame FLOORS

## OPENING TRIMMER

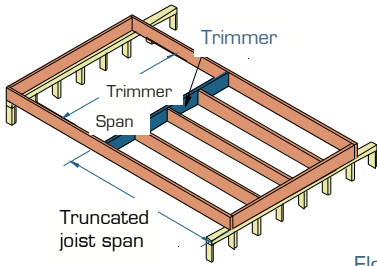

The tables below are for trimmer members of SmartJoists and LVL. Other SmartFrame engineered timber products may also be used for this member, the designs for each of these other material types can be simply calculated by using the SmartFrame software or by contacting the SmartData Customer HelpLine on 1300 668 690 or at smartdata@tilling.com.au.

Floor live load 1.5 kPa

SmartJoist	Maximum trimmer span (mm)				
	Truncated joist span (mm)				
	1.5	3.0	4.5	6.0	7.2
SJ20044	3700	3000	2600	2300	2100
SJ24040	4000	3300	2900	2600	2400
SJ24051	4300	3500	3100	2800	2500
SJ24070	4600	3800	3400	3000	2800
SJ24090	4800	4000	3500	3300	3000
SJ30040	4600	3800	3400	3100	2800
SJ30051	4900	3900	3600	3300	3100
SJ30070	5200	4300	3800	3500	3300
SJ30090	5500	4500	4000	3700	3500
SJ36058	5600	4700	4200	3800	3600
SJ36090	6100	5000	4500	4100	3900
SJ40090	6500	5400	4800	4400	4100

Floor live load 1.5 kPa

SmartLVL 15	Maximum trimmer span (mm)				
	Truncated joist span (mm)				
	1.5	3.0	4.5	6.0	7.2
200x42	3900	3200	2800	2500	2300
240x42	4500	3800	3300	3000	2800
300x42	5300	4500	4000	3700	3500
360x42	6100	5100	4600	4300	4100
200x58	4300	3600	3100	2800	2600
240x58	4900	4100	3700	3400	3100
300x58	5800	4900	4400	4100	3900
360x58	6600	5600	5000	4700	4400
400x58	7100	6000	5400	5000	4800

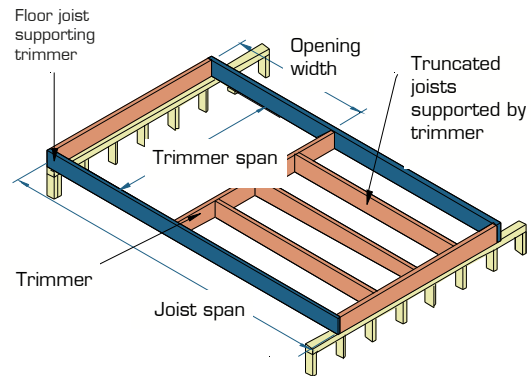

## TRIMMER JOISTS

Trimming joists at floor opening often support the loads from stair stringers, as well as the concentrated load from the trimmer. The table below has been set up to allow a load from stairs equally supported from the floor below (or above) and the trimmer joists. In many cases this will provide a conservative result. Alternative designs can be readily obtained by using the SmartFrame software or by contacting the SmartData Customer HelpLine on 1300 668 690 or at smartdata@tilling.com.au

Floor live load 1.5 kPa

Note: Based on spacing of 600 mm and maximum of 10 mm DL deflection

SmartFrame engineered timber	Maximum trimming joist span (m)											
	Opening width 900 (mm)				Opening width 1800 (mm)				Opening width 2700 (mm)			
	Trimmer span (mm)				Trimmer span (mm)				Trimmer span (mm)			
	2	3	4	5	2	3	4	5	2	3	4	5
SJ20044	3300	3100	2800	2600	3400	3200	3100	3000	3700	3600	3600	3500
SJ24040	3700	3400	3200	3000	3600	3400	3100	3000	4000	3800	3700	3700
SJ24051	3900	3600	3400	3200	3800	3600	3400	3300	4100	4000	3900	3800
SJ24070	4200	3900	3700	3500	4100	3800	3600	3500	4400	4200	4000	4000
SJ24090	4500	4100	3900	3700	4300	4000	3800	3600	4500	4300	4200	4000
SJ30040	4300	4000	3700	3500	4100	3900	3700	3500	4400	4200	4100	3900
SJ30051	4500	4200	3900	3700	4300	4000	3800	3700	4600	4400	4200	4100
SJ30070	4900	4500	4200	4000	4600	4300	4100	3900	4800	4600	4400	4300
SJ30090	5100	4800	4500	4200	4900	4500	4300	4100	5100	4700	4500	4400
SJ36058	5300	4900	4700	4400	5000	4600	4400	4200	5200	4800	4600	4400
SJ36090	5700	5300	5000	4800	5400	5000	4800	4400	5500	5100	4900	4700
SJ40090	6100	5800	5500	5200	5800	5300	5000	4800	5800	5400	5100	4900
200x42	3600	3200	2900	2700	3600	3300	3100	3000	4000	3900	3700	3600
240x42	4200	3800	3500	3300	4100	3800	3600	3400	4400	4200	4000	3900
300x42	5100	4600	4300	4100	4800	4400	4100	4000	5000	4700	4500	4300
360x42	6000	5400	5100	4800	5500	5000	4700	4500	5600	5200	5000	4800
200x58	3900	3600	3300	3000	3900	3600	3400	3200	4200	4000	3900	3900
240x58	4600	4200	3900	3700	4400	4100	3800	3700	4700	4400	4200	4100
300x58	5600	5100	4800	4500	5200	4800	4500	4300	5300	5000	4800	4600
360x58	6600	6000	5600	5300	6000	5500	5100	4900	6000	5600	5300	5100
400x58	7200	6600	6200	5700	6500	6000	5600	5300	6500	6000	5700	5400

# SmartJoist CANTILEVERS SUPPORTING LOAD BEARING WALLS

SmartJoist cantilevers may need to be reinforced to support load bearing walls at the end of the cantilever. The table below lists the allowable roof load widths with un-reinforced and reinforced SmartJoists.

Reinforcement Description:

- 0 - Reinforcement not required
- 1 - Install 15 mm F11 x 1200 mm min structural ply on one side of joist
- 2 - Install 15 mm F11 x 1200 mm min structural ply on both sides of joist or double joist at cantilever
- x - Not suitable

Tables assume a 0.8 kN/m wall dead load, sheet roof dead load of 40 kg/m<sup>2</sup> and tiled roof dead load of 90 kg/m<sup>2</sup>.

Serviceability Limits on Cantilever - DL: 6.0 mm Max,  
- LL: 4.5 mm Max

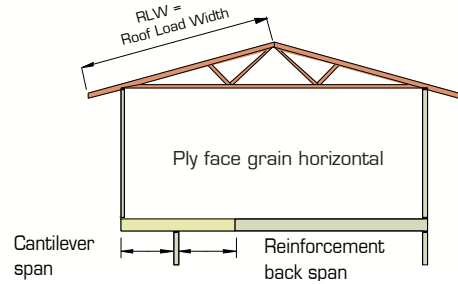

## REINFORCEMENT REQUIREMENTS FOR CANTILEVERED FLOOR JOISTS SUPPORTING LOAD BEARING WALLS \*

\* Important : See notes on next page on the use of this table

**NOTE - Total length cantilever reinforcement must be a minimum of 1200 mm but NEVER be less than twice the cantilever span. i.e. Reinforcement back span ≥ cantilever span.**

Max Cantilever (mm)	RLW (m)	Sheet Roof 40 kg/m <sup>2</sup>									Tiled Roof 90 kg/m <sup>2</sup>														
		4.0			6.0			8.0			2.0			4.0			6.0			8.0					
		SmartJoist	300	450	600	300	450	600	300	450	600	300	450	600	300	450	600	300	450	600	300	450	600		
300	SJ20044	0	0	0	0	0	0	0	0	0	0	0	0	0	0	0	0	0	0	0	0	0	0	0	0
	SJ24040	0	0	0	0	0	0	0	0	0	0	0	0	0	0	0	0	0	0	0	0	0	0	0	0
	SJ24051	0	0	0	0	0	0	0	0	0	0	0	0	0	0	0	0	0	0	0	0	0	1	0	0
	SJ24070	0	0	0	0	0	0	0	0	0	0	0	0	0	0	0	0	0	0	0	0	0	1	0	0
	SJ24090	0	0	0	0	0	0	0	0	0	0	0	0	0	0	0	0	0	0	0	0	0	1	0	0
	SJ30040	0	0	0	0	0	0	0	0	0	0	0	0	0	0	0	0	0	0	0	0	0	0	0	0
	SJ30051	0	0	0	0	0	0	0	0	0	0	0	0	0	0	0	0	0	0	0	0	0	0	0	0
	SJ30070	0	0	0	0	0	0	0	0	0	0	0	0	0	0	0	0	0	0	0	0	0	0	0	0
	SJ30090	0	0	0	0	0	0	0	0	0	0	0	0	0	0	0	0	0	0	0	0	0	0	0	0
	SJ36058	0	0	0	0	0	0	0	0	0	0	0	0	0	0	0	0	0	0	0	0	0	0	0	0
600	SJ20044	0	0	0	0	0	0	0	0	1	0	0	0	0	0	0	0	0	0	0	0	0	1	0	1
	SJ24040	0	0	0	0	0	0	0	0	0	0	0	0	0	0	0	0	0	0	0	0	0	0	0	1
	SJ24051	0	0	0	0	0	0	0	0	0	0	0	0	0	0	0	0	0	0	0	0	0	0	0	x
	SJ24070	0	0	0	0	0	0	0	0	0	0	0	0	0	0	0	0	0	0	0	0	0	0	0	x
	SJ24090	0	0	0	0	0	0	0	0	0	0	0	0	0	0	0	0	0	0	0	0	0	0	0	x
	SJ30040	0	0	0	0	0	0	0	0	0	0	0	0	0	0	0	0	0	0	0	0	0	0	0	0
	SJ30051	0	0	0	0	0	0	0	0	0	0	0	0	0	0	0	0	0	0	0	0	0	0	0	0
	SJ30070	0	0	0	0	0	0	0	0	0	0	0	0	0	0	0	0	0	0	0	0	0	0	0	0
	SJ30090	0	0	0	0	0	0	0	0	0	0	0	0	0	0	0	0	0	0	0	0	0	0	0	0
	SJ36058	0	0	0	0	0	0	0	0	0	0	0	0	0	0	0	0	0	0	0	0	0	0	0	0
900	SJ20044	0	0	1	0	0	1	1	1	x	0	0	0	0	2	x	1	x	x	x	x	x	x	x	x
	SJ24040	0	0	0	0	0	0	0	0	1	0	0	0	0	0	1	0	2	x	1	x	x	x	x	x
	SJ24051	0	0	0	0	0	0	0	0	1	0	0	0	0	0	1	0	2	x	1	x	x	x	x	x
	SJ24070	0	0	0	0	0	0	0	0	0	0	0	0	0	0	1	0	1	x	x	x	x	x	x	x
	SJ24090	0	0	0	0	0	0	0	0	0	0	0	0	0	0	0	0	0	x	0	1	x	0	0	x
	SJ30040	0	0	0	0	0	0	0	0	0	0	0	0	0	0	0	0	0	0	0	0	1	x	0	x
	SJ30051	0	0	0	0	0	0	0	0	0	0	0	0	0	0	0	0	0	0	0	0	1	x	0	x
	SJ30070	0	0	0	0	0	0	0	0	0	0	0	0	0	0	0	0	0	0	0	0	0	1	2	0
	SJ30090	0	0	0	0	0	0	0	0	0	0	0	0	0	0	0	0	0	0	0	0	0	0	0	0
	SJ36058	0	0	0	0	0	0	0	0	0	0	0	0	0	0	0	0	0	0	0	0	0	0	0	0
1200	SJ20044	0	1	x	x	x	x	x	x	x	x	x	x	x	x	x	x	x	x	x	x	x	x	x	x
	SJ24040	0	0	x	x	x	x	x	x	x	0	x	x	x	x	x	x	x	x	x	x	x	x	x	x
	SJ24051	0	0	0	1	2	x	x	x	x	0	0	x	x	x	x	x	x	x	x	x	x	x	x	x
	SJ24070	0	0	0	0	1	2	X	X	X	0	0	x	x	x	x	x	x	x	x	x	x	x	x	x
	SJ24090	0	0	0	0	0	2	0	2	x	0	0	0	0	x	x	x	x	x	x	x	x	x	x	x
	SJ30040	0	0	0	0	0	0	0	0	x	0	0	0	1	2	x	x	x	x	x	x	x	x	x	x
	SJ30051	0	0	0	0	0	0	0	0	0	0	0	0	0	1	2	x	x	x	x	x	x	x	x	x
	SJ30070	0	0	0	0	0	0	0	0	0	0	0	0	0	1	x	x	x	x	x	x	x	x	x	x
	SJ30090	0	0	0	0	0	0	0	0	0	0	0	0	0	0	0	0	1	x	x	x	x	x	x	x
	SJ36058	0	0	0	0	0	0	0	0	0	0	0	0	0	0	0	0	1	x	x	x	x	x	x	x

Spans in the preceding table are based upon a uniform roof load width at the cantilever end of each joist. The presence of large windows or openings within the load bearing wall supported by these cantilevered joists create concentrated loads at the edges of such openings. The joists supporting the concentrated loads will require special engineering consideration to avoid excess loads and differential deflections between adjacent joists. It is strongly recommended that where concentrated loads occur on cantilevered joists that advice be sought from the SmartData Customer HelpLine on 1300 668 690 or at [smartdata@tilling.com.au](mailto:smartdata@tilling.com.au).

## EXAMPLE CONSTRUCTION DETAILS FOR LOAD-BEARING CANTILEVERS

Note: Option 1 with cantilever reinforced with an extra SmartJoist is equivalent to option 2 with 2 sheets of ply reinforcement.

### OPTION 1 - CANTILEVER REINFORCED WITH EXTRA SmartJoist

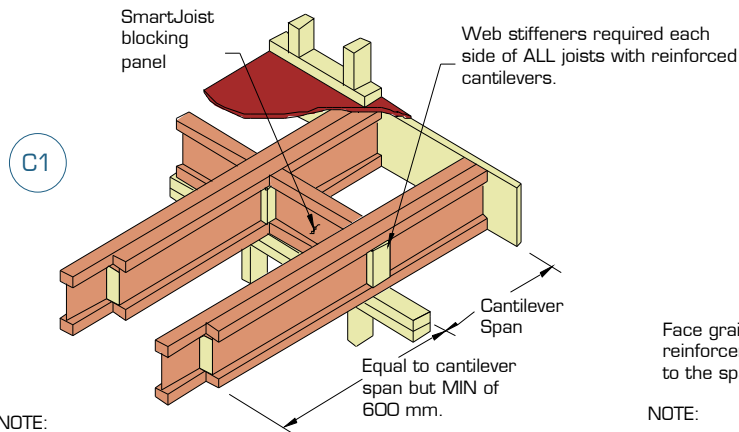

NOTE:

Block together full length with filler blocks as per detail F15 of the SmartJoist Design Guide.

### OPTION 2 - CANTILEVER REINFORCED WITH 1 or 2 SHEETS OF REINFORCING PLY.

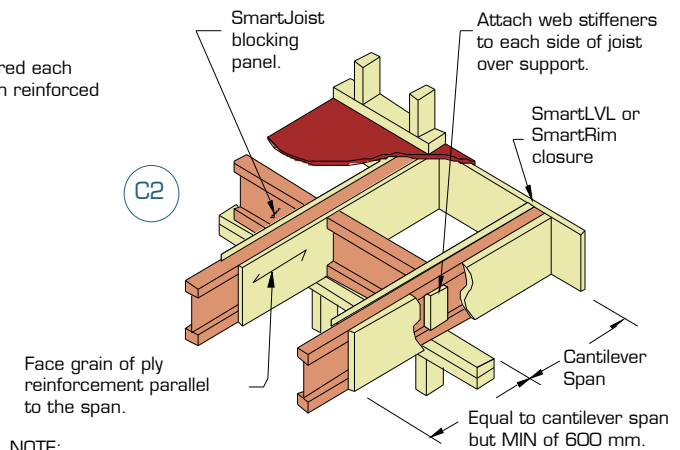

NOTE:

15 mm F11 structural ply is required on one (P1) or both sides (P2) of the joist. (See Tables). Depth shall match the full height of the SmartJoist. Nail with 3.15 x 65 Nails at 100 mm ctrs in a staggered pattern.

## SmartJoists SUPPORTING PARALLEL LOAD-BEARING WALLS

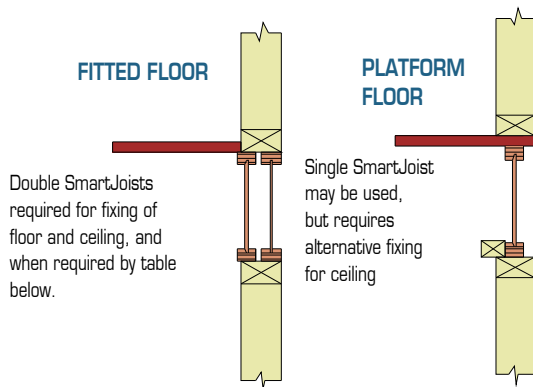

### JOISTS CONTINUOUSLY SUPPORTED BY WALL

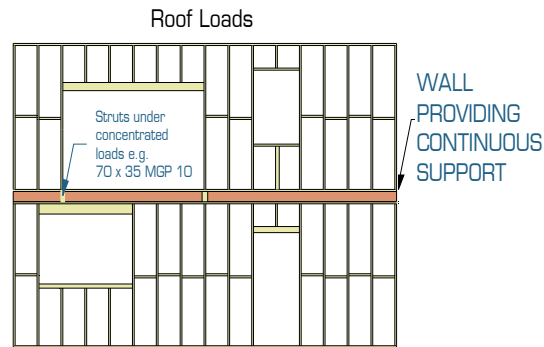

### JOISTS NOT CONTINUOUSLY SUPPORTED BY WALL

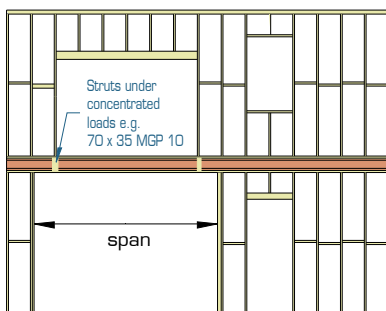

Single (and Double) SmartJoists are adequate to transfer uniformly distributed compression loads up to 29 kN/m per joist from load bearing walls to a continuous rigid support below. Detail F5 is to be used where concentrated loads are to be transmitted through the SmartFrame floor system.

The table below gives allowable spans for single or double floor joists NOT continuously supported by a parallel wall under. Care must be taken to adequately support the web of the joists from concentrated point loads, by the use of detail F5.

# SINGLE SmartJoists SUPPORTING PARALLEL LOAD BEARING WALLS

Floor Load Width (mm)		900			1200			1500		
Roof Load Width (mm)	Roof mass (kg/m <sup>2</sup> )	1500	3000	5000	1500	3000	5000	1500	3000	5000
SmartJoist		Maximum Single span (mm)								
SJ20044	40	2800	2400	2100	2600	2300	2000	2400	2400	1900
	90	2400	1900	1600	2200	1900	1500	2100	1800	1400
SJ24040	40	3100	2800	2400	2900	2600	2300	2700	2500	2200
	90	2700	2200	1900	2500	2100	1800	2400	2100	1800
SJ24051	40	3200	2900	2600	3100	2800	2500	2900	2700	2400
	90	2900	2400	2000	2700	2300	1900	2600	2200	1800
SJ24070	40	3500	3100	2900	3300	3000	2700	3100	2900	2600
	90	3100	2600	2200	3000	2500	2100	2900	2400	2000
SJ24090	40	3700	3200	3000	3500	3200	2900	3300	3100	2800
	90	3300	2800	2300	3100	2700	2300	3000	2600	2200
SJ30040	40	3600	3200	2900	3300	3100	2800	3200	3000	2900
	90	3100	2700	2300	3000	2600	2200	2900	2500	2100
SJ30051	40	3700	3400	3100	3500	3200	3000	3300	3100	2900
	90	3300	2900	2400	3200	2900	2400	3100	2700	2300
SJ30070	40	4000	3600	3300	3800	3500	3200	3600	3300	3100
	90	3500	3100	2700	3400	3000	2600	3300	2900	2500
SJ30090	40	4200	3800	3500	4000	3700	3400	3800	3500	3300
	90	3700	3200	2900	3600	3200	2800	3500	3100	2700
SJ36058	40	4300	3900	3600	4100	3800	3500	3900	3600	3400
	90	3800	3400	3000	3700	3300	2900	3600	3200	2700
SJ36090	40	4700	4200	3900	4400	4100	3700	4200	3900	3600
	90	4200	3600	3200	4000	3500	3100	3900	3400	3100
SJ40090	40	5000	4500	4100	4700	4300	4000	4500	4200	3900
	90	4400	3900	3400	4300	3800	3300	4100	3700	3300
		Maximum Continuous span (mm)								
SJ20044	40	3700	3300	2900	3500	3200	2800	3200	3000	2600
	90	3300	2500	1800	3100	2400	1700	2900	2200	1600
SJ24040	40	3800	3300	2800	3400	3100	2700	3100	2900	2600
	90	3200	2600	2100	3000	2500	2100	2800	2400	2100
SJ24051	40	4200	3800	3400	4000	3700	3200	3700	3500	3100
	90	3800	3100	2300	3600	2900	2200	3400	2800	2100
SJ24070	40	4500	4100	3800	4300	3900	3600	4100	3800	3500
	90	4000	3500	2500	3900	3200	2400	3700	3000	2300
SJ24090	40	4800	4300	4000	4500	4200	3800	4300	4000	3700
	90	4300	3700	2700	4100	3500	2600	4000	3300	2500
SJ30040	40	3900	3300	2900	3500	3100	2800	3200	3000	2700
	90	3200	2600	2200	3100	2500	2200	2900	2500	2100
SJ30051	40	4700	4100	3500	4300	3800	3400	3900	3600	3200
	90	4000	3200	2700	3700	3100	2600	3500	3000	2500
SJ30070	40	5100	4700	4300	4900	4500	4200	4700	4300	4000
	90	4600	4000	3200	4400	3800	3000	4300	3700	2900
SJ30090	40	5400	5000	4500	5100	4800	4400	4900	4600	4300
	90	4900	4200	3500	4700	4100	3300	4500	4000	3200
SJ36058	40	5600	4900	4300	5200	4600	4100	4700	4400	3900
	90	4800	3900	3300	4500	3800	3200	4300	3600	3000
SJ36090	40	6000	5500	5000	5700	5300	4900	5500	5100	4700
	90	5400	4700	3900	5200	4600	3800	5000	4500	3600
SJ40090	40	6400	5800	5300	6100	5600	5200	5800	5400	5000
	90	5700	5000	4200	5500	4900	4000	5300	4800	3900

**NOTES:**

1. bearing lengths - minimum of 30 mm
2. wall loads assumed 0.37 kPa
3. floor load loads 1.5 kPa or 1.8 kN point live load.
4. upper floor dead load 40 kg/m<sup>2</sup>
5. deflection limits: permanent load - span/300 or 12 mm max LL - span/360 or 9 mm max.

# DOUBLE SmartJoists SUPPORTING PARALLEL LOAD BEARING WALLS

Floor load Width (mm)		900			1200			1500		
Roof load Width (mm)	Roof mass (kg/m <sup>2</sup> )	1500	3000	5000	1500	3000	5000	1500	3000	5000
SmartJoist		Maximum Single span (mm)								
2/SJ20044	40	3500	3200	2900	3300	3100	2800	3200	3000	2700
	90	3100	2700	2300	3000	2600	2200	2900	2500	2200
2/SJ24040	40	3800	3500	3200	3600	3400	3100	3500	3300	3000
	90	3400	3000	2600	3300	3000	2600	3200	2900	2500
2/SJ24051	40	4000	3700	3400	3800	3600	3300	3700	3400	3200
	90	3600	3200	2800	3500	3100	2700	3400	3000	2700
2/SJ24070	40	4300	4000	3600	4100	3800	3500	3900	3700	3400
	90	3900	3400	3000	3700	3300	3000	3600	3300	2900
2/SJ24090	40	4600	4200	3800	4300	4000	3700	4200	3900	3600
	90	4100	3600	3200	4000	3500	3200	3800	3400	3100
2/SJ30040	40	4400	4000	3700	4100	3800	3600	4000	3700	3500
	90	3900	3500	3100	3800	3400	3000	3700	3300	3000
2/SJ30051	40	4600	4200	3900	4400	4100	3800	4200	3900	3700
	90	4100	3700	3300	4000	3600	3200	3900	3500	3200
2/SJ30070	40	4900	4500	4100	4700	4300	4000	4500	4200	3900
	90	4400	3900	3500	4300	3800	3400	4100	3700	3400
2/SJ30090	40	5200	4800	4400	5000	4600	4200	4700	4400	4100
	90	4700	4100	3700	4500	4000	3600	4400	3900	3500
2/SJ36058	40	5300	4900	4500	5100	4700	4400	4800	4500	4200
	90	4800	4200	3800	4600	4100	3700	4500	4000	3600
2/SJ36090	40	5800	5300	4900	5500	5100	4700	5300	4900	4600
	90	5200	4600	4100	5000	4500	4000	4800	4400	3900
2/SJ40090	40	6100	5600	5200	5800	5400	5000	5600	5200	4900
	90	5500	4900	4300	5300	4700	4300	5100	4600	4200
		Maximum Continuous span (mm)								
2/SJ20044	40	4400	4000	3500	4100	3700	3300	3800	3500	3200
	90	3900	3100	2600	3600	3000	2600	3500	2900	2500
2/SJ24040	40	4100	3600	3100	3800	3400	3000	3500	3200	2900
	90	3500	2900	2400	3300	2800	2300	3100	2700	2300
2/SJ24051	40	5100	4500	3900	4700	4200	3700	4300	4000	3600
	90	4300	3600	3000	4100	3400	2900	3900	3300	2800
2/SJ24070	40	5400	5000	4600	5200	4800	4400	5000	4600	4300
	90	4900	4300	3800	4700	4200	3700	4600	4100	3600
2/SJ24090	40	5800	5300	4800	5500	5100	4700	5300	4900	4600
	90	5200	4600	4100	5000	4500	4000	4800	4400	3900
2/SJ30040	40	4100	3500	3100	3700	3300	2900	3400	3100	2800
	90	3400	2800	2400	3200	2700	2300	3100	2600	2300
2/SJ30051	40	5000	4400	3800	4600	4100	3700	4300	3900	3500
	90	4300	3500	2900	4000	3400	2900	3800	3300	2800
2/SJ30070	40	6200	5700	5000	5900	5400	4700	5500	5100	4600
	90	5500	4500	3800	5200	4400	3700	5000	4200	3600
2/SJ30090	40	6600	6000	5500	6300	5800	5400	6000	5600	5200
	90	5900	5200	4600	5700	5100	4600	5500	5000	4500
2/SJ36058	40	6100	5300	4600	5500	5000	4400	5100	4700	4200
	90	5100	4200	3500	4800	4100	3500	4600	3900	3400
2/SJ36090	40	7300	6700	6100	6900	6400	6000	6600	6200	5700
	90	6600	5700	4800	6300	5500	4700	6100	5300	4600
2/SJ40090	40	7700	7100	6200	7400	6700	5900	6900	6400	5700
	90	7000	5700	4700	6600	5400	4600	6200	5300	4500

**NOTES:**

1. bearing lengths - minimum of 30 mm
2. wall loads assumed 0.37 kPa
3. floor load Loads 1.5 kPa or 1.8 kN point live load.
4. upper floor dead load 40 kg/m<sup>2</sup>
5. deflection limits: permanent load - span/300 or 12 mm max LL - span/360 or 9 mm max.

# SmartRim HOLE SPECIFICATIONS

The maximum allowable hole size for a SmartRim shall be  $\frac{1}{3}$  of the Rim Board depth as shown below.

The length of the Rim Board segment containing a hole shall be at least 8 times the hole size.

**RIM BOARD HOLE SIZES AND MINIMUM LENGTH**

SmartRim Depth (mm)	Maximum allowable hole size <sup>(a)</sup> <sup>(b)</sup> (mm)	Minimum length of SmartRim board segment <sup>(c)</sup> for the maximum allowable hole size (mm)
200	130	1050
240	160	1280
300	200	1600
360	235	1900
400	265	2100

- (a) These hole provisions do not apply to SmartRim installed over openings such as doors or windows
- (b) The diameter of the round hole or the longer dimension of the rectangular hole
- (c) The lengths of the SmartRim segment per wall line. For multiple holes, the minimum length of SmartRim segment shall be 8 times the sum of all hole sizes

## Application Notes.

- Do not cut holes in SmartRim installed over openings, such as doors or windows, where the SmartRim is not fully supported, except that holes of 40 mm or less in size are permitted provided they are positioned at the middle depth and in the middle  $\frac{1}{3}$  of the span ( see note 5 for minimum hole spacing).
- Field-cut holes should be vertically centred in the Rim Board and at least one hole diameter or 150 mm whichever is less, clear distance away from the end of the wall line. Holes should never be placed such that they interfere with the attachment of the Rim Board to the ends of the floor joist, or any other code-required nailing.

## RIM BOARD OVER AN OPENING

Do not cut holes in Rim Board over an opening except for holes of 40 mm or less in size (see note 1).

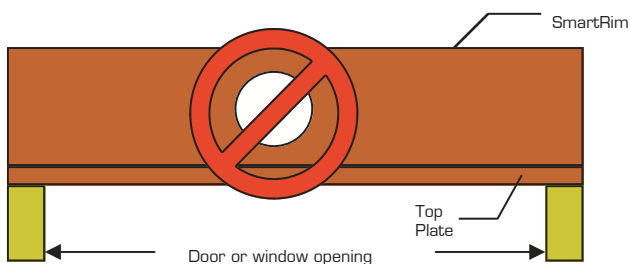

3. While round holes are preferred, rectangular holes may be used providing the corners are not over-cut. Slightly rounding corners or pre-drilled corners with a 25 mm diameter bit is recommended.

4. when concentrated loads are present on the Rim Board (loads not supported by any other vertical-load-carrying members such as squash blocks), holes should not be placed in the Rim Board within a distance equal to the depth of the Rim Board from the area of loading.

## RIM BOARD NEAR CONCENTRATED VERTICAL LOAD

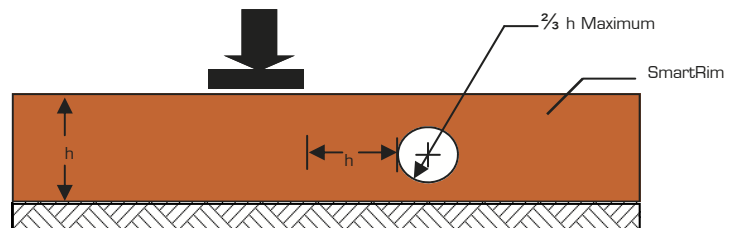

5. For multiple holes, the clear spacing between holes shall be at least two times the diameter of the larger hole, or twice the length of the longest rectangular hole. This minimum hole spacing does not apply to holes of 40 mm or less in diameter, which can be placed anywhere in the Rim Board (see note 1 for holes over opening) except that the clear distance to the adjacent hole shall be 75 mm minimum.

## MULTIPLE HOLES FOR RIM BOARD

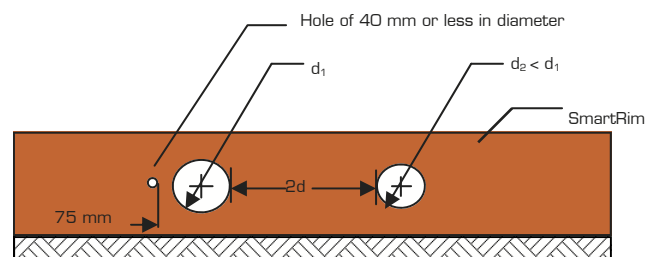

6. All holes shall be cut in a workman-like manner in accordance with the limitations listed above.

# SmartJoist ROOF DETAILS

## ABOUT ROOFS

Roof members are subject to dead and live loads as well as wind loads. These wind loads can act either down onto the roof, or can create an uplift effect. For roofs of light construction, the uplift loads generally control the maximum span, whereas it is usual for dead and live loads to be the controlling factors for heavier roofs (e.g. tiles). SmartJoists, by their large depth to width ratio, perform well in roof situations providing that their upper and lower flanges have adequate lateral support provided by battens and/or ceiling materials. Due to this fact, the spans in the table below only apply for roofs which meet the following criteria:

- Enclosed building
- Ceiling fastened to the underside of bottom flange or adequate lateral supports to bottom flange at a minimum of 600 mm centres

- Roofs are constructed as per details R1 to R9 of this manual
- Batten spacings at a maximum of 1200 centres.

## TIE DOWN

Wind loadings on light roofs can produce net uplift pressures. The same requirements and methods of tie down apply to SmartJoists as for solid timber roof members except that any tie down system must extend over the top flange. Guidance for tie down requirements are provided in AS1684.

## Wind Classification N1 - N3

Max Deflections DL: Span/300 LL: Span/250  
WL: Span/150. Max Slope = 25°.

Joist Code	Roof mass (kg/m <sup>2</sup> )	Single span @ 25° pitch				Continuous 2 span @ 25° pitch			
		Rafter/Roof Beam spacing (mm)							
		450	600	900	1200	450	600	900	1200
Recommended maximum rafter span - Plan dimension (mm)									
SJ20044	40	5000	4600	4000	3650	N/A <sup>(1)</sup>	N/A <sup>(1)</sup>	N/A <sup>(1)</sup>	4550
	90	3850	3500	3050	2750	N/A <sup>(1)</sup>	4900	4250	3800
SJ24040*	40	5600	5150	4500	4100	N/A <sup>(1)</sup>	N/A <sup>(1)</sup>	4850	4300
	90	4350	3950	3450	3100	N/A <sup>(1)</sup>	4750	4050	3550
SJ24051	40	6000	5550	4850	4450	N/A <sup>(1)</sup>	N/A <sup>(1)</sup>	N/A <sup>(1)</sup>	5200
	90	4700	4250	3700	3350	N/A <sup>(1)</sup>	N/A <sup>(1)</sup>	4950	4350
SJ24070	40	6600	6050	5350	4850	N/A <sup>(1)</sup>	N/A <sup>(1)</sup>	N/A <sup>(1)</sup>	N/A <sup>(1)</sup>
	90	5100	4650	4050	3650	N/A <sup>(1)</sup>	N/A <sup>(1)</sup>	N/A <sup>(1)</sup>	N/A <sup>(1)</sup>
SJ24090	40	7000	6500	5750	5250	N/A <sup>(1)</sup>	N/A <sup>(1)</sup>	N/A <sup>(1)</sup>	N/A <sup>(1)</sup>
	90	5500	5050	4400	3950	N/A <sup>(1)</sup>	N/A <sup>(1)</sup>	N/A <sup>(1)</sup>	N/A <sup>(1)</sup>
SJ30040*	40	6600	6100	5400	4850	N/A <sup>(1)</sup>	N/A <sup>(1)</sup>	N/A <sup>(1)</sup>	N/A <sup>(1)</sup>
	90	5200	4700	4100	3700	N/A <sup>(1)</sup>	N/A <sup>(1)</sup>	N/A <sup>(1)</sup>	N/A <sup>(1)</sup>
SJ30051	40	7100	6550	5800	5300	N/A <sup>(1)</sup>	N/A <sup>(1)</sup>	N/A <sup>(1)</sup>	N/A <sup>(1)</sup>
	90	5600	5050	4450	4000	N/A <sup>(1)</sup>	N/A <sup>(1)</sup>	N/A <sup>(1)</sup>	N/A <sup>(1)</sup>
SJ30070	40	7800	7200	6350	5800	N/A <sup>(1)</sup>	N/A <sup>(1)</sup>	N/A <sup>(1)</sup>	N/A <sup>(1)</sup>
	90	6100	5550	4850	4400	N/A <sup>(1)</sup>	N/A <sup>(1)</sup>	N/A <sup>(1)</sup>	N/A <sup>(1)</sup>
SJ30090	40	8250	7700	6800	6250	N/A <sup>(1)</sup>	N/A <sup>(1)</sup>	N/A <sup>(1)</sup>	N/A <sup>(1)</sup>
	90	6550	6000	5200	4700	N/A <sup>(1)</sup>	N/A <sup>(1)</sup>	N/A <sup>(1)</sup>	N/A <sup>(1)</sup>
SJ36058	40	8450	7950	7000	6400	N/A <sup>(1)</sup>	N/A <sup>(1)</sup>	N/A <sup>(1)</sup>	N/A <sup>(1)</sup>
	90	6750	6150	5400	4850	N/A <sup>(1)</sup>	N/A <sup>(1)</sup>	N/A <sup>(1)</sup>	N/A <sup>(1)</sup>
SJ36090	40	9150	8650	7800	7150	N/A <sup>(1)</sup>	N/A <sup>(1)</sup>	N/A <sup>(1)</sup>	N/A <sup>(1)</sup>
	90	7550	6900	6000	5450	N/A <sup>(1)</sup>	N/A <sup>(1)</sup>	N/A <sup>(1)</sup>	N/A <sup>(1)</sup>
SJ40090	40	9650	9150	8350	7750	N/A <sup>(1)</sup>	N/A <sup>(1)</sup>	N/A <sup>(1)</sup>	N/A <sup>(1)</sup>
	90	8150	7450	6500	5900	N/A <sup>(1)</sup>	N/A <sup>(1)</sup>	N/A <sup>(1)</sup>	N/A <sup>(1)</sup>

NOTE: <sup>(1)</sup>Maximum Continuous spans exceed the maximum available length of the SmartJoist

\*Product not available in NSW

## SLOPED ROOF SPAN AND CUT LENGTHS

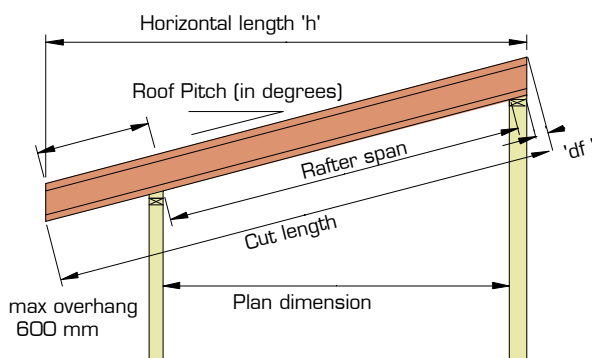

Roof slope degrees	Slope factor 'sf'	Depth factor 'df'				
		Joist depth (mm)				
		200	240	300	360	400
15	1.04	54	64	80	96	107
17.5	1.05	63	76	95	113	126
20	1.06	73	88	109	131	146
22.5	1.08	83	99	124	149	166
25	1.10	93	112	140	168	187
27.5	1.13	104	125	156	187	208
30	1.15	115	139	173	208	231
35	1.22	140	168	210	252	280

span (mm) = plan dimension x slope factor (sf)  
Cut length (mm) = horizontal length (h) x slope factor (sf) + depth factor (df) = h x sf + df

# TYPICAL SmartJoist ROOF DETAILS

**WARNING: Do not allow workers or loads on roof until ALL blocking, hangers, bracing and nailing is completed. SEE SAFETY WARNING.**

## BIRDSMOUTH CUT (At low end of joist ONLY)

(Limited to Joist spacing of MAX of 600 mm)

Birdsmouth cut shall bear fully and not overhang the inside face of the plate.

Web stiffeners required each side of SmartJoist. Bevel cut stiffeners to match roof slope. See Detail F13.

2 of 3.15 x 65 nails (one each side)

### WEB STIFFENERS

See Filler Block details Nail with 5 of 3.15 mm dia nails and clinch.

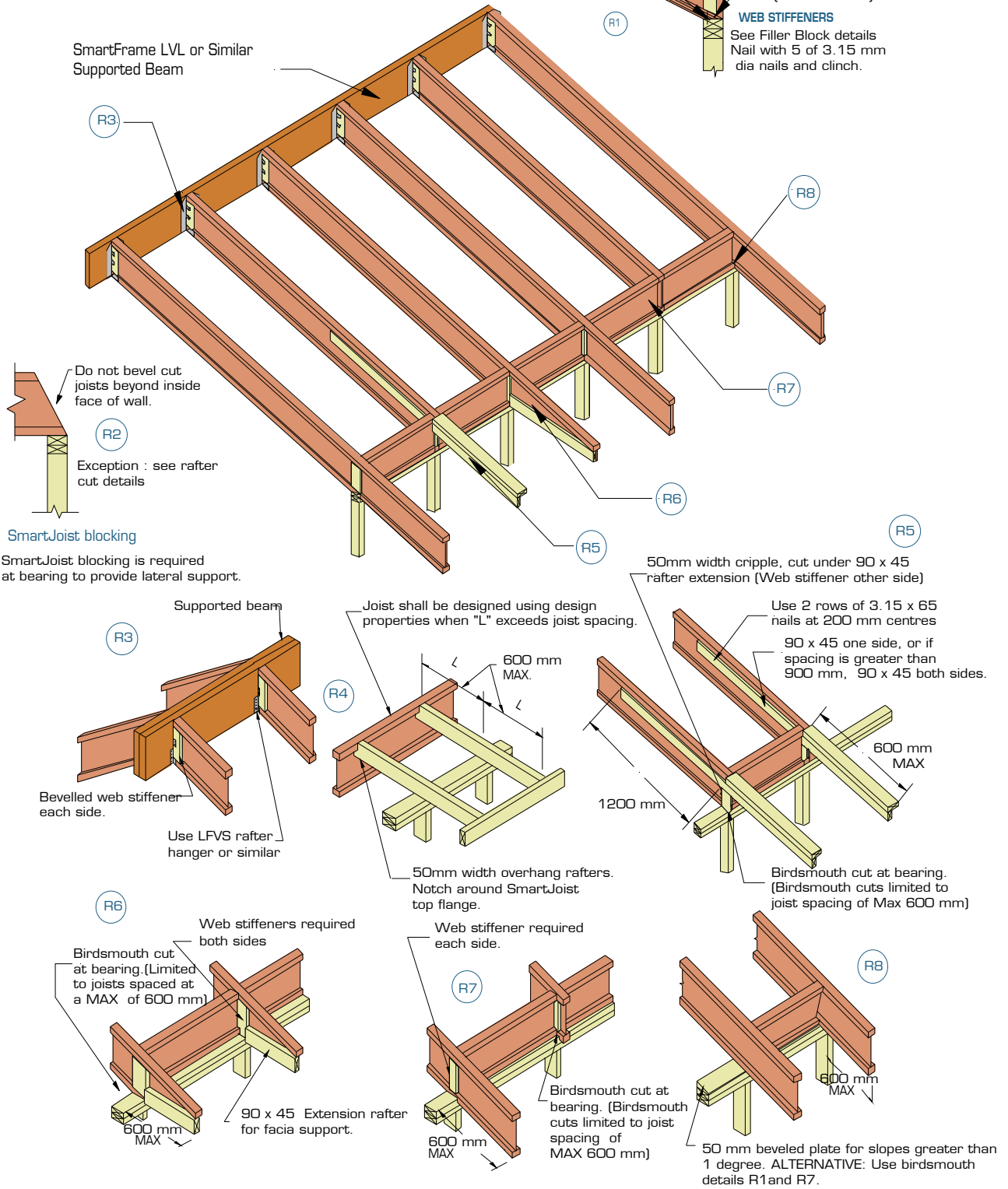

## SmartJoist RAFTER TIE DOWN

SmartJoist rafters need to be tied down in wind uplift situations in a similar manner to solid timber as shown in section 9 of AS 1684. The examples shown in this section are equally applicable to SmartJoists except that web stiffeners as per detail F13 and R1 must be installed to the SmartJoists where either skewed nails or framing anchors are chosen as the tie down method before the uplift capacities in the tables in section 9 of AS 1684 can be adopted.

All tie down types that involve a strap over the top of the SmartJoist rafters, or involving the bolting down of a member above the rafter running in the perpendicular direction, require no modification to the SmartJoist and the uplift capacities in the tables in section 9 of AS 1684 may be used.

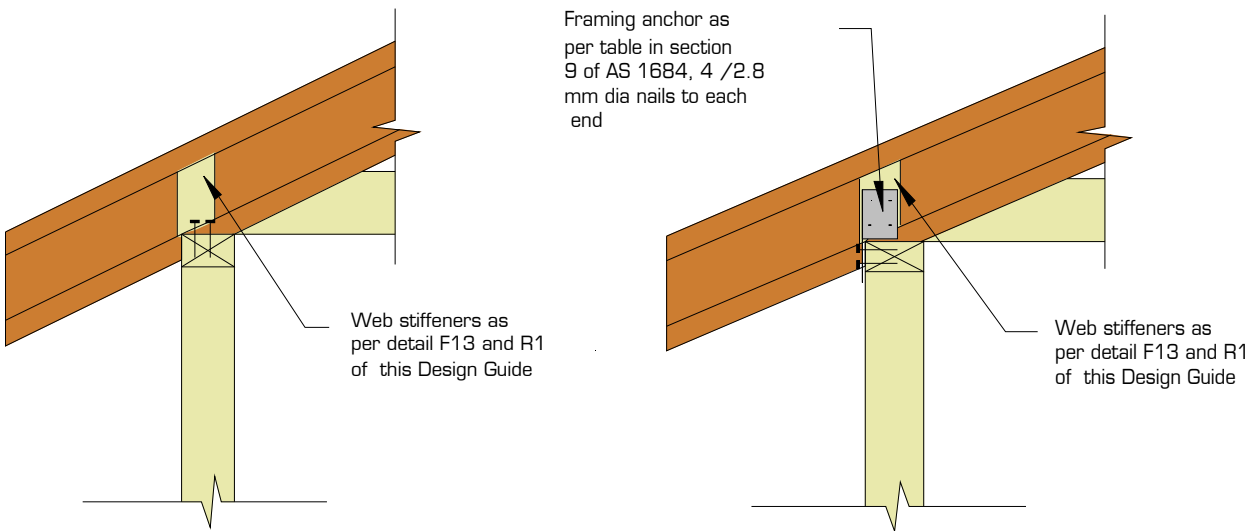

## TYPICAL SmartJoist RAFTER BOX GUTTER REBATE DETAILS

### BOX GUTTER REBATES

Rebates for box gutters are permissible within a roof constructed with SmartJoist rafters to the MAXIMUM rebate limits as shown below.

Fig BG1 with 2 pieces of 90 x 45 nailed to the web reduces shear capacity by 40%  
 Fig BG2 with 2 pieces of 17 mm F14 ply nailed to the web maintains full shear capacity

Given that the design shear values at the end of rafters with lightweight roofs are usually very low compared to the allowable shear, in most instances fig BG1 is satisfactory

to provide a box gutter rebate within the SmartJoist rafters, however the remaining shear capacity MUST be checked.

It is recommended that designers wishing to cut box gutter rebates in SmartJoist rafter contact the SmartData Customer Helpline on 1300 668 690 or at [smartdata@tilling.com.au](mailto:smartdata@tilling.com.au) for further advice on this issue.

### SmartJoist box gutter rebate details

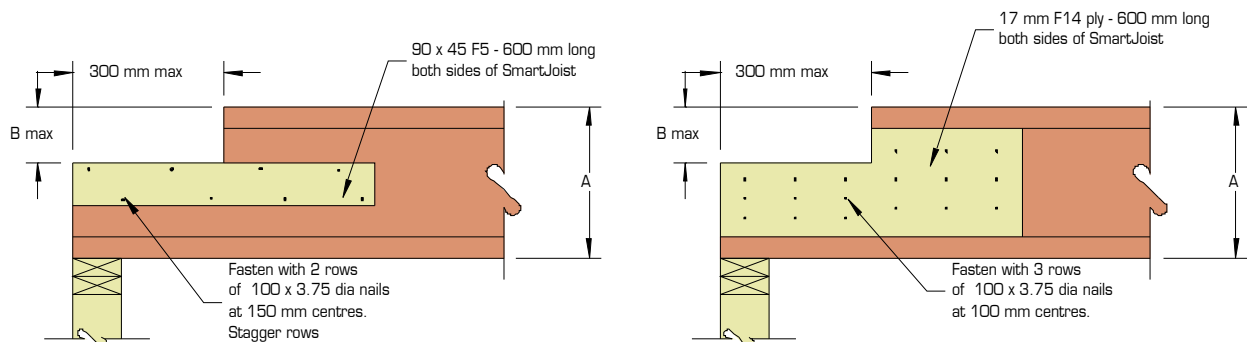

A = 200\*, 240 & 300 mm depth

B = 50 mm when A = 200\* & 240 mm  
 B = 100 mm when A = 300 mm

\* 200 mm - Requires ply infill, 90 x 45 solid timber reinforcement is NOT suitable

# GENERAL CONNECTOR INSTALLATION DETAILS

## POSITIVE ANGLE NAILING

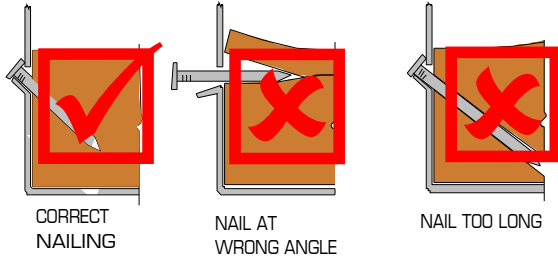

## TOP MOUNT HANGERS

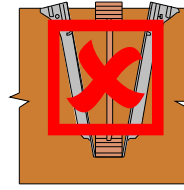

**HANGER OVER SPREAD**  
If hanger is overspread, I-Joist may be raised above header, also, NO support for top flange.

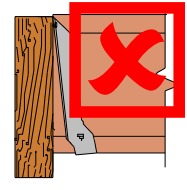

**HANGER NOT PLUMB**  
A hanger kicked out from the header can cause uneven surfaces.

## PREVENT ROTATION

Hangers provide some joist rotation resistance; however, additional lateral restraint may be required for deep joists.

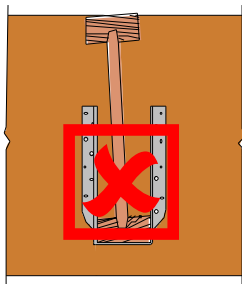

**NO WEB RESISTANCE RESULTS IN ROTATION**

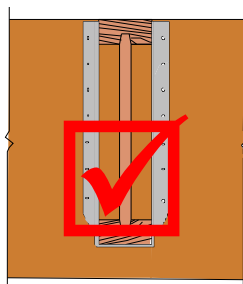

**NO WEB STIFFENER REQUIRED**  
Hanger side flange supports joist top flange.

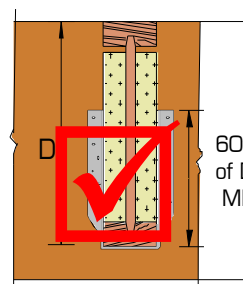

**WEB STIFFENER REQUIRED**  
Hanger side flange should be at least 60% of joist depth or potential joist rotation must be addressed.

## CORRECT FASTENERS



Bracket capacities are based upon using the correct bracket nail as per the table on page 6. Bracket nails have special heads to provide strength. Clouts, brads etc are NOT suitable as bracket nails

## I-JOIST HEADERS

Backer blocking each side, hanger nails must extend past the supporting joist's web member into the backer blocking.

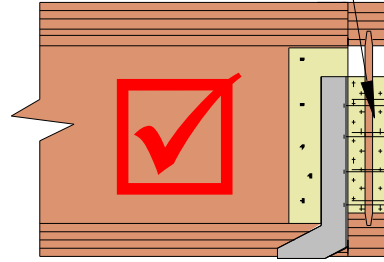
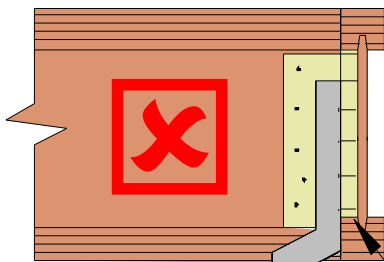

**FACE MOUNT CONNECTION TO WEB**

Bottom flange pulling off when Backer block on one side only.

The top flange of the supporting joist must be supported by backer blocks to prevent cross grain bending and rotation.

**TOP MOUNT CONNECTION**

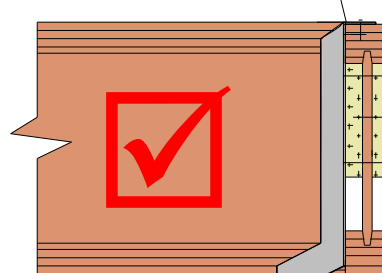
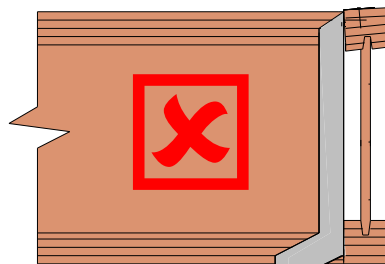

# FIRE SAFETY AND SOUND TRANSMISSION

## FIRE SAFETY

The Building code of Australia became a performance-based code in 1996 (BCA96). The introduction of the BCA along with the changes to AS1530.4 has seen Australia brought into line with international standards for fire resistance testing. The principle modification has been to express the test result in terms of the performance of the specimen Fire Resistance Level (FRL) rather than to assign a single rating as had been the established practice. The outcome of the test is expressed as the number of minutes for which the specimen fulfils the requirements of each of the three criteria, being:

- a) Structural adequacy
- b) Integrity; and
- c) Insulation, and expressed in that order

The performance of a specimen is then given as the actual time for which the specimen satisfied these criteria, but rounded down to the nearest regulatory requirements. E.g. 60/60/60.

Ceiling systems may also be required to provide "Resistance to the Incipient Spread of fire" for a given period of time. This requires the ceiling system to prevent the spread of fire within a roof/ceiling or floor/ceiling cavity by providing adequate thermal insulation to combustibles in this area, avoiding the danger of them igniting. To coincide with the changes, the timber industry produced a set of manuals Multi Residential Timber Framed Construction (MRTFC) 1, 2 & 3, which outlined the BCA requirements for multi residential buildings, design criteria and construction details which were designed to satisfy the BCA requirements.

## FIRE RATED FLOORS/CEILINGS

The best information available at this time concludes that the fire resistance for ceiling and floor/ceilings is achieved by the lining material and that alternative joist sizes and material can be substituted in the various certified systems, providing they are designed to support the full loads. The thickness of the fire grade ceiling lining for the relevant FRL is the same as required in the tested systems using solid timber joists.

Additional testing have concluded that the following layers of fire rated plasterboard can achieve the FRL and incipient spread of fire as listed in the following table:

Fire grade plasterboard	FRL	Incipient spread of fire
1 x 13 mm	30/30/30	0
1 x 16 mm	60/60/60	30
2 x 13 mm	60/60/60	30
2 x 16 mm	90/90/90	60
3 x 16 mm	120/120/120	60

The above ratings can be achieved using standard fire grade plasterboard from some sheet manufacturers. Other manufacturers may however require the use of special fire rated board or may still require the number of layers outlined in MRTFC 2.

For further details on the various certified systems, see the MRTFC manuals available through all State Timber Development Associations or contact the engineers on the SmartData Customer HelpLine on 1300 668 690.

## SOUND TRANSMISSION

The ability of walls and floors to reduce noise is measured over the most important part of the hearing range (from 125 to 4000 cycles per second), and the results reduced to a "weighted sound reduction index" or  $R_w$  value. In 2004, the BCA introduced the addition of a Spectrum Adaption factor. This  $C_{tr}$  factor takes into account lower frequency level sounds, and has been chosen in large part, in recognition of the problem of the high bass frequency outputs of modern home theatre systems and amplified music systems. Therefore, both the  $C_{tr}$  and the  $R_w$  of the building element will now need to be considered.

In addition to being rated for airborne sound transmission, floors are also rated by "Impact sound pressure level" or  $L'_{n,w}$  plus the spectrum adaption factor  $C_i$  values that rate the capacity of floor assemblies to control impact noise such as footfalls. The lower the  $L'_{n,w} + C_i$  of the floor, the better the performance of the floor in terms of impact sound insulation

The BCA now requires a  $R_w + C_{tr}$  of 50 in floors between sole occupancy units and between dwellings and a plant room, lift shaft, stairway, public corridor, public lobby or similar.

In 2004, the BCA introduced Deemed-to-satisfy provisions which require the  $L'_{n,w} + C_i$  of a floor to be determined by testing in the laboratory. The impact sound insulation requirements for floors in the BCA is  $L'_{n,w} + C_i$  not more than 62 for floor separating dwellings and floor separating dwellings from a plant room, lift shaft, stairway, public corridor, public lobby or similar.

The use of light-frame construction systems challenges designers to insulate against noise rather than simply relying on the massiveness of heavy walls and floors. Excellent levels of noise control can be achieved with good acoustics in wood framed structures surfaced with wood structural panels. Sound control can be achieved by applying floor and wall materials over isolated air spaces that absorb sound. The addition of resilient channels to support the ceiling system independently increases the  $R_w + C_{tr}$  and  $L'_{n,w} + C_i$  ratings.

The best current understanding indicates that the "Certified Systems – Walls, Floors and Ceiling" as detailed in the MRTFC 2 can be used to closely approximate the  $R_w + C_{tr}$  and  $L'_{n,w} + C_i$  rating of floor/ceiling systems with SmartJoist floor joists. Work is under way to further investigate the link between joist types and impact sound insulation.

For further details on the various certified systems, see the MRTFC manuals available through all State Timber Development Associations or contact the engineers on the SmartData Customer HelpLine on 1300 668 690 or at smartdata@tilling.com.au

## SmartGuard™ TREATMENT

The treatment of timber to extend its service life is covered by AS/NZS 1604. This code identifies the various biological hazards by a hazard class number, with hazard class numbers from H1 - H6. The higher the hazard class number, the greater the severity of the biological hazard. A complete table listing the 6 hazard classes is contained within AS/NZS 1604.1.

All SmartJoists can be supplied SmartGuard treated to either H2s as per the table below, or alternatively may be after-market LOSP H2 treated by an experienced and approved timber preserver.

Water borne treatments are NOT suitable for SmartJoists. It is also NOT recommended that SmartJoists be specified for use outside above ground, even if H3 treated. This is predominately due to the geometric shape of the I-Joist which will not shed water effectively.

Further information on SmartGuard treated I-Joists can be obtained on 1300 668 690 or at smardata@tilling.com.au

\* All SmartJoists are manufactured from materials not susceptible to Lyctid attack

Hazard Class	Exposure	Specific service conditions	Biological hazard	Typical uses
H1*	inside, above ground	Completely protected from the weather and well ventilated, and protected from termites	Lyctid borers	Interior beams, stair cases, stringers
H2s	inside, above ground	<b>South of the Tropic of Capricorn ONLY</b> Protected from weather, Nil leaching	Borers and termites	Interior joists, rafters and roof beams
H2	inside, above ground	Protected from weather, Nil leaching	Borers and termites	Interior joists, rafters and roof beams

## ADHESIVE AND FORMALDEHYDE EMISSION FACTS

**Q.** Are the glues used in SmartFrame Engineered Wood Products safe?

**A.** Yes, they are safe, Phenolic resins used in our Engineered Wood Products are stable, polymerised materials. The polymerisation reaction is non-reversible (i.e. once the polymer is formed, it doesn't break down). A wood dust warning label is provided for all SmartFrame wood products to alert our customers that wood dust can be generated by sawing, sanding, or machining wood and wood products.

**Q.** What is the level of formaldehyde emission from our phenolic-bonded Engineered Wood Products?

**A.** Independent third party testing has confirmed that formaldehyde emissions from our phenolic-bonded products (i.e.. OSB, LVL, I-Joists, and Glulam) are below 0.5 mg/L under reasonably foreseeable conditions of use, which meets or exceeds the E<sub>0</sub> Formaldehyde Emission Class

In short, all available information indicates that formaldehyde levels associated with phenolic resin-bonded wood products are similar to those of the dimension lumber veneer or other forms of wood used to make the products.

**Q.** How much formaldehyde is in our phenolic-bonded, Engineered Wood Products?

**A.** The amount of formaldehyde in our Engineered Wood Products is less than 0.1 percent of the dry weight.

**Q.** What is being done to reduce the exposure to formaldehyde?

**A.** Formaldehyde is normally present at low levels, usually lower than 0.03 ppm, in both outdoor and indoor air. Efforts have been made by both government and industry to reduce exposure to formaldehyde. A 1985 regulation by the US Department of Housing and Urban Development (HUD), covering the use of manufactured pressed wood products in housing was designed to ensure that indoor levels were below 0.4 ppm. Product standards established for plywood and particleboard led to significant reductions in formaldehyde emissions from those products. Furthermore, HUD acknowledged that phenolic resin bonded wood products emitted such small quantities of formaldehyde that these products were exempted from all the testing and certification requirements of the standards. In Germany, the German Hazardous Materials regulation, better known as the "E1" Standard, sets a limit of 1.0 mg/L for formaldehyde emissions from some wood-based composite products. All available data indicates that our phenolic bonded Engineered Wood Products meet the more stringent E<sub>0</sub> level.

**Q.** What affects formaldehyde levels in a home?

**A.** Formaldehyde levels in the indoor air depend mainly on what is releasing the formaldehyde, the temperature, the humidity, and the air exchange rate (i.e. the amount of outdoor air entering or leaving the indoor area) Levels of formaldehyde decrease with increasing air exchange rate, decreasing temperature, and decreasing humidity.

## DrillMate® Smart Saw

Developed to address industry concerns regarding Occupational Health & Safety (the use of power tools overhead), Australian made Smart Saw provides carpenters, plumbers, heating and cooling installers, engineering and mechanical trades people a safe easy to use drilling system.



The Drillmate Smart Saw is a complete kit including the drill press, channel stem adaptor, V block adaptor for pipe drilling, SmartFrame adjustable clamping bracket and a 152 mm hole saw with arbor.



Requiring no body force, self supporting Smart Saw will carry its own weight enabling the user to maintain a comfortable working position.

Ideally suited to use with I-Joist applications, Smart Saw will perform with a wide range of wood based products, solid timber and more.



Compatible with air or electric drills with a 43 mm neck, Smart Saw Drillmate I-Joist clamping bracket is compatible with I-Joists from 240 to 400 mm.

The unique design of the bracket system eliminates twisting and grabbing making it easier to use. Drill a clean and neat 152 mm hole through an I-Joist in around 30 seconds. Over cutting and unacceptable alternatives will be a thing of the past.



Rectangular or larger penetrations are simply created by overlapping the hole saw two or three times.



### SET UP

1. Remove the Drillmate Smart Saw from the box.
2. Remove the two un-breako bolts from the side of the press.
3. Bolt the SmartFrame adjustable clamp bracket to Drillmate. The longer bracket is fitted on the bottom facing in, and reversed for joists 300 mm and up. Place the smaller part of the bracket on top and bolt to Drillmate.
4. Mount the bracket to Drillmate and attach the drill and hole saw.
5. The final adjustment—clamp the bracket to ensure a firm fit inside the I-Joist flanges.
6. The illustrations demonstrate use from both a front and rear view.

Drillmate® is a registered trademark of Drillmate P/L Australia



# SMARTFRAME DESIGN COMPENDIUM

## Design Compendium Contents

Specification Software

- Technical Support

Design Guides (pdf)

Technical Illustrations (dxf/dwg for CAD)

Fixing Details - fixing details/hangers (jpg)

Video Clips - installation/company (mpg)

Software Tutorial

## Interactive



## Printable



## PC

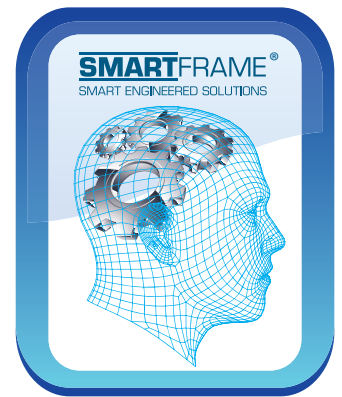

Never before has so much user friendly computer power been unleashed into the hands of building industry professionals to allow the design and detailing of engineered timber products. This software, in conjunction with the SmartFrame Design Centre and SmartFrame engineered timber products themselves, combines to form the most sophisticated structural timber option ever available to the Australian market. The SmartFrame Engineered Timber Solution represents an entirely new and revolutionary concept in the delivery of 21st century technology and service to the building industry.

Available From:

**Head Office**  
31-45 Orchard Street,  
Kilsyth, Victoria 3137

email: [sales@tilling.com.au](mailto:sales@tilling.com.au)

Phone +61 3 9725 0222  
Fax +61 3 9725 3045

**New South Wales**  
109 Kurrajong Avenue,  
Mt Druiitt, NSW 2770

email: [nswsales@tilling.com.au](mailto:nswsales@tilling.com.au)

Phone +61 2 9677 2600  
Fax +61 2 9677 2500

**Queensland**  
20-24 Nealdon Drive,  
Meadowbrook, QLD, 4131

email: [qldsals@tilling.com.au](mailto:qldsals@tilling.com.au)

Phone +61 7 3440 5400  
Fax +61 7 3440 5444

**Western Australia**  
10 Cartwright Drive,  
Forrestdale, WA 6112

email: [wasales@tilling.com.au](mailto:wasales@tilling.com.au)

Phone +61 8 9248 7643  
Fax +61 8 9248 3241



[www.tilling.com.au](http://www.tilling.com.au)

Proudly Australian Owned

